

SAHAMATI NEPAL

Gaindakot - 5, Nawalparasi, Nepal

**TECHNICAL SPECIFICATION
FOR
THE CONSTRUCTION OF MARKET CENTER
AT NAWALPARASI**

SUBMITTED BY:

Bonafide Engineering Consultancy Pvt. Ltd.

Sanepa, Lalitpur

Email: bonafideengineering@gmail.com

Contact: 01-5403222, 9851182816

Web: www.bonafide.com.np

Specifications of Building Construction (Civil) Works

1. General

The Work shall be carried out according to these Specifications and whenever the Specifications are not given, the relevant Nepal Standards or Indian Standards will be considered as final and binding.

The Work shall be carried on till it is completed satisfactorily along with the completion of other essential services. The building Contractor shall keep the other Contractors informed of the proposed program of Work, well in advance, so that the building Work is not hindered. The Contractor shall further cooperate with other Contractors in respect of any facility required by them e.g. making holes in shuttering for sanitary, pipes, electric conduits, fan hook etc. However, no extra payment shall be admissible for such reasonable assistance and facilities afforded to other Contractors and the building Contractors shall be deemed to have taken these factors into consideration while quoting the rates.

The Work shall be related to the drawings which the Contractor is presumed to have studied. Nothing extra will be paid for any item because of its shape, location or other difficult circumstances, even if the schedule makes no distinction, as long as the item is shown in the drawings.

The sources of materials stated in the Specifications are those from which materials are generally available. However, materials not conforming to Specifications shall be rejected even if they come from the stated sources. The Contractor should satisfy himself that sufficient quantity of materials of acceptable Specification is available from the stated or other sources.

The requirements of Specifications shall be fulfilled by the Contractor without extra charges i.e. the item rates quoted shall be deemed to have taken these Specifications into account.

These are requirements the Contractor shall fulfil after the issue of Letter of Acceptance but before the Date of Commencement.

1.1 Definitions

General:

Acceptable/Approved (Approval) - Acceptable to/approved by the Engineer.

Agreed - Agreed in writing.

As detailed - As detailed on the drawings.

Authorized/ordered/rejected - Authorized/ordered/rejected by the Engineer.

Designated - Shown on the drawings or otherwise specified by the Engineer or, in relation to an item scheduled in the bid documents, descriptive of an item to be priced by a bidder.

Indicated - Indicated in or reasonably to be inferred from the contract, or indicated in

Instructed/directed/permitted - Instructed/directed/ permitted by the Engineer.

Satisfactory - Capable of fulfilling or having fulfilled the intended function.

Service - Any pipeline, cable, duct etc. for conveying or transmitting any fluid or other matter.

Submitted - Submitted with the tender or submitted to the Engineer, as appropriate.

Tolerances:

Deviation - The difference between the actual (i.e., measured) size or position and the specified size or position.

Permissible deviation - The specified limit(s) of deviation.

Tolerance - The range between the limits within which a size or position must lie.

Measurement and Payment:

Bill/schedule - The bill/schedule of quantities.

Billed/scheduled rate - The unit rate or price entered in the bill/schedule at which the Contractor undertakes to execute the particular work or to provide the required material, article or service, or to do any or all of these things, as set out in the item concerned.

Billed/scheduled - Listed in the bill/schedule of quantities.

Fixed charge - A charge for work that is executed without reference to time.

Method-related charge - The sum for an item inserted in the bill by the Contractor when tendering, to cover items of work relating to his intended method of executing the Works.

Time-related charge - *A charge for work the cost of which, to the Employer, is varied in proportion to the length of time taken to execute the particular item scheduled.*

Value-related charge - A charge that is directly proportional to the value of the contract.

1.2 Contractor’s Office & Accommodation

Space allocated for storage of various materials such as cement, reinforcement steel, and petroleum products etc. shall be clearly separated to avoid contamination.

The Contractor shall provide at his own expense adequate temporary accommodation and toilet facilities for his Workmen and keep the same in good conditions. The Contractor shall make his own arrangement for the supply of electric power and lighting as required for construction purpose.

The Contractor shall make his own arrangement for all internal and external telephones and other communication means deemed necessary for the Works.

The Contractor shall make his own arrangement for office equipment and other consumable for his use for the Works.

1.3 Safety Measures

The Contractor shall be responsible for safety of all workmen and other persons entering the Works and shall at his own expense; where not stated otherwise take all measures, necessary to ensure their safety.

The Contractor shall ensure that all his Employees are fully conversant with the regulations, emergency and rescue procedures etc. and shall enforce a rule that will instantly dismiss any employee committing a serious breach of such regulations.

1.4 Notice Boards

The Contractor shall erect notice boards at the site giving details of the Contract in the format and wordings directed by the Engineer. The board shall be removed by the Contractor by the end of the

Defects

Liability

Period.

1. Temporary Facilities:

1.1 Protection of Adjoining Property

The Contractor shall control the movement of his crews and equipment on right-of-way including access routes approved by the Engineer so as to minimize damage to crops and property and shall endeavour to avoid marring the lands. Ruts and scars shall be obliterated and damage to land shall be corrected and the land shall be restored as closely as possible to its original conditions before final taking-over of the Works.

The Contractor shall be responsible directly to the Employer for any excessive or avoidable damage to crops or lands resulting from his operations whether on lands adjacent to right-of-way or on approved access road and deductions will be made from payment due to the Contractor to cover the amount of such excessive or avoidable damage as determined by the Engineer.

1.2 Insurance of works

- **Insurance of Works**
 - The Contractor shall take out Insurance for the Works from approved agency/institution staff if provided in the contract
 - Payments made to the agency/institution and stamp charges/duties incurred if any, by the contractor in compliance of the above work shall be paid from Provisional Sum included for the item in the BOQ after submission of the insurance document to the satisfaction of the Engineer.
- **Third Party Insurance**
 - The Contractor shall take out Third Party Insurance from an approved agency/institution staff if provided in the contract
 - Payments made to the agency/institution and stamp charges/duties incurred if any, by the Contractor in compliance of the above work shall be paid from the Provisional Sum included for the item in the BOQ after submission of the documents to the satisfaction of the Engineer.
- **Insurance of Contractor's Workmen and Employees**
 - The Contractor shall insure against such liability as stipulated in Conditions of Particular Application.
 - The cost for works under this Sub-Clause shall be covered by the Contractor's overhead included in unit rates of other items in the BOQ.

1.3 Environmental Protection Works

The environment has been defined to mean surrounding area including human and natural resources to be affected by execution and after completion of works.

The Contractor shall take all precautions for safeguarding the environment during the course of the construction of the works. He shall abide by all prevalent laws, rules and regulations governing pollution and environmental protection.

The Contractor shall prohibit employees from unauthorized use of explosives, poaching wildlife and cutting trees. The Contractor shall be responsible for the action of his employees.

The Contractor is expected to arrange and execute the Works in such a way that existing environmental conditions are not deteriorated. Borrow pits and dumping sites used by the contractor shall be reinstated at his own cost by grass and/or tree plantation.

Written instruction/approval must be given to seek from the Engineer regarding protection and reinstatement of environment throughout the Contract period. Failure in compliance with Engineer's instructions in respect of overall standard will lead to reduction or withhold of payment. Further, any serious deterioration in the environment including pollution attributable to Contractor as determined by the Engineer, may result in deduction of actual expenditures incurred in their

reinstatement done through separate agency, from any money due to the Contractor.

Environmental protection works, among others, shall also include the following:

1.4 Borrow/Quarry Sites

The Engineer shall have the power to disallow the method of construction and/or the use of any borrow/quarry area, if in his opinion, the stability and safety of the works or any adjacent structure is endangered, or there is undue interference with the natural or artificial drainage, or the method or use of the area will promote undue erosion.

All areas susceptible to erosion shall be protected as soon as possible either by temporary or permanent drainage works. All necessary measures shall be taken to prevent concentration of surface water and to avoid erosion and scouring of slopes and other areas. Any newly formed channels shall be backfilled.

Borrows/quarries shall be located away from the population centres, drinking water intakes, cultivable lands and drainage systems. The cutting of trees shall be minimized. Temporary ditches and/or settling basins shall be dug to prevent erosion. The undesirable ponding of water shall be prevented through temporary drains discharging to natural drainage channels.

Earthworks operations shall be strictly limited to the areas to be occupied by the permanent works and approved borrow areas and quarries unless otherwise permitted by the Engineer. Due provision shall be made for temporary drainage. Erosion and/or instability and/or sediment deposition arising from earthwork operations not in accordance with the Specifications shall be made good immediately by the Contractor.

The Contractor shall obtain the permission of the Engineer before opening up any borrows pits or quarries. Such borrow pits and quarries may be prohibited or restricted in dimensions and depth by the Engineer where:

- (i) They might affect the stability or safety of the works or adjacent property;
- (ii) They might interfere with natural or artificial drainage or irrigation;
- (iii) They may be environmentally unsuitable.

1.5 Disposal of Spoil and Construction Waste

Materials in excess of the requirements for permanent works and unsuitable materials shall be disposed off in locations and in the manner as agreed with the Engineer. The locations of disposal sites shall be such as not to promote instability, destruction of properties and public service systems. Exposed areas of such disposal sites shall be suitably dressed and be planted with suitable vegetation.

The Contractor shall plan his works in such a way that there is no spillage of POL products to the surface or sub-surface water.

1.6 Provision and Maintenance of Camps, Offices, Stores, Equipment Yards

Various works defined under this item are related to provision and maintenance of camps for work person and employees, Contractor's site offices, stores equipment yards and workshops. These camps must be adequate, rain-proof, spacious, airy and hygienic with proper lighting and materials storage facilities. The area shall be kept neat and clean.

Space allocated for storage of materials such as cement, gabion wire, reinforcing wire etc. shall in general be damp-free, rain-proof and away from petroleum products storage.

Permission may be granted by the Engineer to erect suitable camps within the right of way free of charge, if such establishments do not cause obstructions to traffic, nuisance to works execution and adverse effect to the environment.

Written information must be given to and approval be taken from the Engineer regarding proper establishment and maintenance of such camps. Failure in compliance with Engineer's instruction in respect of overall standard will lead to reduction or with holding of payment.

1.7 Provision and Maintenance of Toilets

Provision of toilets for labor and employees shall be made to avoid public nuisance as well as pollution of water courses and air. The Contractor shall construct suitable septic tanks and/or soak pits along with room of pit-type latrines. Sufficient water must be provided and maintained in the toilets. Proper methods of sanitation and hygiene should be employed during the whole project duration.

1.8 Provision of Potable Water

The Contractor shall supply potable water along with commencement of work to Contractor's staff and work person both at camps and construction-sites. This arrangement shall be enforced to avoid proliferation and generation of various water borne diseases.

The Contractor shall inform the Engineer regarding sources, installation and operation of supply of potable water within a week after the supply is commenced.

1.9 Provision of First Aid/Medical Facilities

Provision of first aid/medical facilities shall be made along with commencement of work to provide quick medical service to injured/sick work person, and employees. Services shall also include on-the-way service and other arrangements required for taking them to the nearest hospital in case of emergency.

The scope of work shall include service of at least one part-time experienced health worker/health assistant with a minimum of once a week full time site visit as work assignment. The Contractor shall also supply and provide adequate medicines and facilities required for standard first aid.

The Contractor shall inform the Engineer regarding the medical facility within a week after its establishment and operation.

1.10 Hazardous Materials

The Contractor shall not store hazardous materials near water surfaces. The Contractor shall provide protective clothing or appliances when it is necessary to use some hazardous substances. High concentration of airborne dust resulting in deposition and damage to crops and water resources shall be avoided. The Contractor shall take every precaution to control excessive noise resulting in disruption to wildlife and human population.

Only controlled explosives methods shall be applied and used in construction works.

1.11 Reinstatement of Environment

The Contractor shall arrange and execute works as well as related activities in such a way that environmental conditions are reinstated. He may be required to carry out filling, removal and disposal works along with plantation of grass and trees as directed by the Engineer at his own costs at identified locations to reinstate environment.

Written instruction/approval shall be given by/sought from the Engineer regarding reinstatement of environment both during and after completion of works and up to the end of Defects Liability Period.

2. Measurement and Payment

No separate measurement and payment shall be made for the works described in this Clause.

2.1. Survey and Setting Out

- During the period of Commencement of works the Contractor shall survey the construction area and confirm the levels. He shall immediately notify the Engineer of any discrepancies and shall agree with the Engineer any amended values to be used during the contract, including replacements for any stations missing from the original stations.
- The Contractor shall check, replace and supplement as necessary the station points and agree any revised or additional station details with the Engineer.
- All stations and reference points shall be clearly marked and protected to the satisfaction of the Engineer.
- The Contractor shall establish working Bench Marks tied with reference stations soon after taking possession of the site. The coordinates and the elevations of the reference stations shall be obtained from the Engineer. The working Bench Marks shall be near all major/medium structure sites. Regular checking of these Bench Marks shall be made and adjustments, if any, got agreed with the Engineer and recorded.
- The Contractor shall be responsible for the accurate establishment of the centrelines based on the Drawing and data supplied. The centrelines shall be accurately referenced in a manner satisfactory to the Engineer. A schedule of reference dimensions shall be prepared and supplied by the Contractor to the Engineer.
- The existing profile and cross-sections shall be taken jointly by the Engineer and the Contractor. These shall form the basis for the measurements and payments. If in the opinion of the Engineer, design modifications of the centrelines and/or grade are advisable, the Engineer shall issue detailed instructions to the Contractor and the Contractor shall perform modifications in the field, as required, and modify the levels on the cross-sections accordingly.

2.2. As-Built Drawings

Such approved Working Drawings as have been selected by the Engineer shall be correctly modified for inclusion in the As-Built Drawings incorporating such variations to the Works as have been ordered and executed. Such drawings shall show the actual arrangement of all structures and items of equipment installed under the Contract. The Contractor shall submit 1 (one) reproducible copy and 3 (three) prints of all As-Built Drawings clearly named as such to the Engineer for approval before applying for the Taking-Over Certificate for the respective Section of the Works.

During the course of the Works, the Contractor shall maintain a fully detailed record of all changes from the approval to facilitate easy and accurate preparation of the As-Built Drawing. Irrespective of the other contractual prerequisites no Section of the Works will be considered substantially completed until the Engineer has approved the respective As-Built Drawings.

2.3. Photographs

The Contractor shall supply negatives and un-mounted positive colour prints of photographs, of such portions of the works in progress and completed, as may be directed by the Engineer. The negatives and prints shall not be retouched. The negative of each photograph shall be the property of the Employer and shall be delivered to the Engineer with prints. No prints from these negatives shall be supplied to anyone without the written permission of the Engineer.

2.4. Supply Of Video Records

The work consists of taking video film of important activities of the work as directed by the Engineer during the contract and editing them to a video film of playing time between 30 minutes and 180 minutes as directed by the Engineer. It shall contain narration of activities in English and/or Nepali by a competent narrator. The edition of the video film and the script shall be approved by the Engineer. The video records shall be of acceptable quality and the film shall be capable of producing colour pictures.

Measurement

The measurement for this item shall be by number of sets of edited master records supplied each with four copies thereof.

Payment

The contract unit rate shall include all expenses for making video films with the help of a professionally competent photographer, editing, narration and supplying the final edited master record along with four copies thereof.

3. Notes About Measurement and Payment

3.1.Measurement

Unless specified, all measurements shall be based on "Principals of Measurement (Int.) for works of constructions." The tolerances specified in these Specifications are for evaluation of accuracies only based on which the work shall be accepted or rejected. However, the measurement of the work performed within the limits of tolerances shall be the measurement of actual work done in place, if their dimensions are less than what have been specified or instructed by the Engineer. If the actual work done in place is more than what has been specified or instructed by the Engineer, but within the limit of tolerances, the measurement shall be the measurement of the work what has been specified or instructed by the Engineer.

3.2.Payment

Unless specified in the contract, the contract unit rates and/or prices for items as set out in the Bill of Quantities are the full and the final compensation to the Contractor for:

- Supply of all materials necessary to complete the item as per relevant specifications;
- Use of materials, labors, tools, equipment, machines and other resources as per need;
- All handling, packing charges and transportation;
- Cost of supervision, quality assurance, temporary and ancillary works;
- Site commissioning;
- Maintenance and making good;
- All duties and obligations as set out in the contract
- general works such as setting out, clearance of site before setting out and after completion of works
- the preparation of detailed work program
- providing samples of various materials proposed to be used
- the detailed Design and Drawing of temporary works
- testing of materials
- any other details as required by the contract
- cost of all operations like storing, erection, moving into final position, etc. necessary to complete and protect the work till handing over to the Employer;
- the cost for safeguarding the environment
- All incidental costs, not covered under above stated.

Where the Bill of Quantities does not include the items mentioned in this Section, no separate payment shall be made for such works. The costs in connection with the execution of the works specified herein shall be considered to be included in the related items of other works specified in the Bill of Quantities or shall be considered to be incidental to the works specified. Items specified in this Section and included in the Bill of Quantities shall be paid at the contract unit rates as agreed and shown in the Bill of Quantities.

3.3.National Specifications

Certain Specifications issued by various national or other widely recognized bodies are referred to in these Specifications. Such Specifications shall be defined and referred to as National Specifications.

The Contractor may propose that the materials and workmanship be defined in accordance with the requirements of other equivalent National Specifications and he may execute the works in accordance with such National Specifications as may be approved by the Engineer. A copy of the National Specification, together with its translation into the English language if the National Specification is in another language, shall be submitted to the Engineer along with the request for its adoption.

In referring to National Specifications, the following abbreviations are used:

NS	Nepal Bureau of Standards and Metrology
IS	Indian Standards
ASTM	American Society of Testing and Materials
BS	British Standards
BSCP	British Standard Code of Practice
ISO	International Organization for Standardization
EN	European Norm
NFP	French Norm

Along with the commencement of the contract, the Contractor shall provide in his site office at least one complete set of all National Specifications referred to in these Specifications, if they are for the Sections applicable to the works. This set shall be made available for use by the Engineer.

3.4. Equivalency of Standards

Wherever reference is made in these Specifications to specific standards and codes to be met by the materials, plant, and other supplies to be furnished, and work to be performed or tested, the provisions of latest current edition or revision of relevant standards and codes in effect shall apply. Other authoritative standards which ensure a substantially equal or higher performance than the specified*, -standards and codes shall be accepted subject to the Engineer's prior review and approval. Differences between the standards specified and the proposed alternative standards shall be fully described by the Contractor and submitted to the Engineer at least 28 days prior to the date when the Contractor desires the Engineer's approval. In the event that the Engineer determines that such proposed deviations do not ensure substantially performance, the Contractor shall comply with the standards and codes specified. No payment shall be made for adoption of higher standards.

3.5. Units of Measurement, Abbreviations and Terminology:

Units of Measurement

The Symbols for units of measurement are used in these Specifications as they are given below.

M	micron = $m \times 10^{-6}$
mm	millimetre
m	meter
km	kilometre
sq. mm. or mm ²	square millimetre
sq.m. or m ²	square meter
sq. km. or km ²	square kilometre

ha	hectare	SG	Specific Gravity
cu. m. or m ³	cubic meter	SI	International Standard Units of Measurements
lit or l	litre		
rad	radian	SSS	Sodium Sulphate Soundness test, loss on 5 cycles
°C	degrees Celsius	STV	Standard Tar Viscosity
kg	kilogram	TS	Tensile Strength
g	gram = kgx10 ⁻³	UC	Uniformity Coefficient
mg	milligram = kg x 10 ⁻⁶	UCS	Unconfined Compressive Strength VIM
mg/l	milligram per litre		Voids in Mix
t	ton = kg x 10 ³	w/c	Water cement ratio
kg/m ³	kilogram per cubic meter	wt	Weight
t/m ³	ton per cubic meter	%	Percent
N	Newton		
N/m ²	Newton per square meter		
Lin. m	Linear meter		
Max	Maximum		Symbols of other units, if not covered above, shall be as per SI system set out in ISO 31/1.
Min	Minimum		

Abbreviations

ACV	Aggregate Crushing Value
BOQ	Bill of Quantities
CR	Crushing Ratio
dia	Diameter
hr	Hour
LS	Linear Shrinkage
MC	Moisture Content
MDD	Maximum Dry Density
min	Minute
no	Number (units), as in 6 no.
No	Number (order) as in No 6
OMC	Optimum Moisture Content
OPC	Ordinary Portland Cement
PI	Plasticity Index
PL	Plastic Limit
PM	Plasticity Modulus (PI x % passing 0.425 mm sieve)
POL	Petrol, Oil & Lubricant
ROW	Right of Way
SE	Sand Equivalent
sec	Second

The following abbreviations are used in these Specifications.

3.6. Program

The Contractor shall provide all information needed for fulfilment of the program and required in accordance with the Conditions of Contract including the sequence in which he intends to work including implementation of quality assurance plan. If the Contractor requests a change in the sequence and such change is approved by the Engineer, the Contractor shall have no claim as per the Conditions of Contract for delay arising from such revisions to the program.

The program for the construction and completion of the works shall be established using CPM/PERT techniques or equivalent. The program shall be detailed enough to give, in addition to construction activities, detailed network activities for the submission and approval of materials, procurement of critical materials and equipment, fabrication of special products/equipments if any and their installation and testing, and for all activities of the Engineer that are likely to affect the progress of work. The Contractor shall update all activities in accordance with the Conditions of Contract on the basis of the decision taken at the periodic site review meetings or as directed by the Engineer.

The program shall also include the Contractor's general requirements for any road closures to be agreed in principle with the Engineer. Such agreement shall not relieve the Contractor of his responsibility to obtain specific approval for each closure or series of closures. Any proposal for night working shall also be stated in the program.

4. QUALITY CONTROL

4.1. Scope

This Section covers the Quality Control System and procedures, Quality Assurance Plan, program of tests, trials, and general procedures for acceptance as well as Laboratory arrangements and related facilities which are required for the selection and control of the quality of materials and workmanship.

4.2. Contractor Responsible For the Quality of the Works

All materials incorporated and all workmanship performed shall be strictly in conformity with the requirements of the Specifications and the Contractor shall be responsible for the quality of the works in the entire construction within the contract.

4.3. Quality Control System

The Quality Control System comprises the methods, procedures and organization for the Quality Control of the works. The Contractor shall implement the Quality Control System in the following sequences:

- a) Compliant testing for materials including Laboratory trials,
- b) Compliant testing for methods and equipment prior to the commencement of the work, including site trials or trials sections,
- c) Control testing during construction,
- d) Acceptant testing on completed works or parts of the works.

The Contractor shall carry out all necessary tests and shall report to the Engineer the results of such tests before submitting materials and/or finished works or part of works to the Engineer for approval in accordance with this Specification. In certain circumstances, tests may be carried out at the place of manufacture as per the Conditions of Contracts.

For satisfying himself about the quality of the works, quality control tests shall be conducted by the Engineer himself or by any other agencies deemed fit by the Engineer. Additional tests may also be conducted where in the opinion of the Engineer such tests are needed.

Before commencement of the work, the Contractor shall demonstrate a trial run of all construction equipment for establishing their capability to achieve the laid down Specifications and tolerances to the satisfaction of the Engineer.

The supply, testing and monitoring shall be in compliance with a Quality Assurance Plan and the provisions in the contract.

4.4. Quality Assurance Plan

The Contractor shall submit to the Engineer for his approval, the Quality Assurance Plan (QAP) which shall be based on the detailed Program of the Works.

The Quality Assurance Plan shall include the following:

- (1) The Quality Control Schedule Comprising of:

- a) The recapitulative test schedule and testing program detailing the list of tests for compliance, Laboratory trials, site trials and trials Sections, construction control tests and their frequencies, tests for acceptance of the completed works with their dates.
 - b) Recapitulative list of "critical" acceptance testing procedures, for equipment or parts of the works which corresponds to the tasks on the Critical Path according to the construction Program.
 - c) Estimate of the number of tests to be carried out, list and number of appropriate equipment to conduct them, list of tests to be conducted outside the site Laboratory , if any, identification of the outside Laboratory where proposed to carry out the test.
 - d) List of staff assigned to the Laboratory, their position and responsibilities in the quality control procedures, their qualification and experience, general description and detailed organization of the Laboratory activities.
- (2) The list of sources of materials and/or of manufactured articles, their main characteristics, their identification mode as provided by the supplier when required; the program of supply and procurement of material and/or manufactured articles in accordance with the Program.
- (3) The list of tests and quality control procedures to be implemented by the Sub-contractors, if any, pointing out the "critical" acceptance testing procedures relating to the Sub-contracted works, which correspond to the tasks on the Critical Path included in the Sub-contracted works.
- The Contractor shall implement the Quality Control in compliance with the approved QAP.

The Engineer's approval of the QAP shall not relieve the Contractor from his responsibility of the quality of the Works as per the Conditions of Contract and these Specifications nor shall the Engineer's approval of the QAP exempt the Contractor of any procedure to inform the Engineer in writing or request for the Engineer's approval or re-approval as specified in the Conditions of Contract and/or in these Specifications

The Contractor shall monitor and update the QAP on the basis of the decisions taken at the periodic review meetings or as directed by the Engineer and in accordance with the program of the works and the Conditions of Contract.

4.5. Testing Procedures And Set Of Tests

For ensuring the quality of the work, the materials and the workmanship shall be subjected to testing in accordance with procedures, sets of tests and frequencies as specified in respective Sections of these Specifications. The specified testing frequencies are not restrictive. The Engineer shall direct for the tests to be carried out as frequently as deemed necessary that the materials and workmanship comply with their Specifications.

Where no specific testing procedure is mentioned in the Specifications, the tests shall be carried out as per the prevalent accepted engineering practice or directions of the Engineer.

4.6. Laboratory Trials To Confirm Compliance With Specifications

Concrete

Laboratory trials for concrete mixes shall be carried out by the Contractor to demonstrate that the composition of the mixes proposed for the concrete meets the requirements of the Specifications.

The compositions of concrete mixes which meet the specified requirements and are accepted by the Engineer shall be then used in the site trials carried out.

Site trials for concrete mixes shall be carried out by the Contractor to demonstrate the suitability of his mixing equipment. During the site trials, compliance with the Specifications for weighing equipment, storage of ingredients, means of transport for concrete, placing, compaction and curing shall be checked by the Engineer.

During the site trial a full scale sequence including placing and compaction of concrete shall be carried out on a part of the works which will represent particular difficulties due to the presence of reinforcement, obstructions or others.

The Contractor shall allow in his program for conducting the site trials and for carrying out the appropriate tests, including the time required to obtain compressive strength test results at 28 days. The Contractor shall inform in writing the Engineer at least two weeks before the date he proposes to use the concrete mixes in the site trials with all relevant data including the trial program, the results of the Laboratory trial tests for the proposed concrete mixes and compliance tests results of all constituents i.e. cement, aggregates, water and admixtures, if any.

4.6.1. Other Works and Equipment

Site trials for Pre-stressed Concrete Works, Painting of Structural Steelwork etc. are detailed in the relevant Sections of these Specifications.

Approval of the Engineer to a set of data recorded in a site trial shall not relieve the Contractor of his responsibilities to comply with the requirements of these Specifications

4.6.2. Control Testing During Construction

Quality Control procedure are detailed in the relevant Sections of these Specifications

4.6.3. Acceptance Tests For Completed Works Or Part Of Works

Acceptance tests for other works and equipment are detailed in the relevant Sections of these Specifications.

4.6.4. Recapitulative Schedule Of Tests

The tests to be carried out and their frequency for the quality control of the works are detailed in the relevant Sections of these Specifications.

The following Table recapitulates the testing schedule for the main types of works.

4.6.5. Testing Schedule

Part or component of the works	Tests	Frequency
Concrete Materials	cement: acceptance tests: Control tests: chemical composition physical	Conservative samples for each supply and not less than every 200t or part of it. testing in case of non

	properties aggregates: acceptance tests: Control tests: Grading Silt & clay content Organic impurities Chloride content, sulphate content, Alkali reactivity	compliance of the mixes or storage on site for longer than 1 month each delivery and every 100 t or part of it for fine aggregate and 250 t or part of it for coarse aggregate As frequently as required.
	Concrete • lab. Trials • site trials • control tests compressive strength	early works: every 6 m ³ of each class. When compliance is established: every 20 m ³ or part of it.
	Reinforcement:	
Brickworks for structures Materials mortar	quality of bricks quality of cement and sand control tests compressive strength of mortar	as required every 10 m ³ of brick work or part of it.
Masonry for structures materials Mortar	quality of cement and sand control tests compressive strength of mortar dismantling of masonry (1 m_1 m)	as required every 10m ³ of masonry of part of it every 30m ³ of masonry or part of it

4.7. Contractor's Laboratory

(1) Laboratory Building

The Contractor shall on his own make provide and maintain a site Laboratory. Such Laboratory shall have a minimum total area of 60 m² appropriately partitioned to house various Laboratory instruments/equipment, office, store, and toilet. It shall have adequate electrical connections (power plugs, switches) necessary to operate the equipment in the Laboratory. The Laboratory shall either be any existing building at site, rented and modified to suit the purpose or shall be a shed constructed of GI sheets and pipes/angles. The floor of the Laboratory shall however be of 100 mm M15/20 concrete and the minimum height 2.7 m. The Contractor shall submit the design of the GI shed for approval of the Engineer prior to its construction.

Alternatively, it may also be constructed from shipping containers modified suitably to the Engineer's satisfaction for the purpose.

This Laboratory shall be part of the Temporary Works and will be the property of the Contractor on completion of the Works.

(2) Measurement

Measurement for the provision of site Laboratory will be on a monthly basis.

(3) Payment

Payment for work will be made on the basis of contract unit price indicated in the BOQ. Payment for the works shall be full and final compensation for all material, labor, and equipment (including land rent if any) to complete the works as specified.

4.8. Laboratory Equipment at Site

The equipment for the site Laboratory and field control tests shall be provided, installed, operated and maintained by the Contractor. The equipment, material, chemical reagents may also be used by the Engineer to conduct tests according to his Quality Check Plan. Testing frequency (both Laboratory and field control) shall be developed in the Quality Assurance Plan of the Contractor and Quality Check Plan of the Engineer. After the completion of the Works, the Laboratory equipment shall become the property of the Contractor. Laboratory and field control equipment anticipated for the Works are listed in following Tables.

Measurement and Payment

Measurement and Payments for the work will be made in relevant monthly statement on the basis of lump sum price quoted in the BOQ. It shall be paid in the following manner:

- 50% after installation of the equipment in the site Laboratory to the satisfaction of the Engineer and
- the remaining 50% after 80% completion of the Works.

4.9. Laboratory Equipment/Field Control Testing Apparatus For Cement Masonry And Concrete Works

S.No.	Designation	Quantity
1.	Slump Cone with Base and Graduated Tamping Rod	2 Sets
2.	Heavy Duty Concrete Cube Moulds, 150 mm cubes, with Base	12 Sets
3.	Concrete Cube Crushing (set) Machine with Spherically Seated Block and Platens for Mortar Test	1 Set
4.	Mortar Flow Apparatus with Cone	2 Sets
5.	Vicat Apparatus	1 Set
6.	Standard Sieves for Aggregate	2 Sets
7.	Electric Oven	1 Set

4.10. Sampling and Testing of Material away From Site

Some tests on construction material shall be conducted periodically off the site at reputable institutions in Kathmandu as directed by the Engineer.

The frequency of tests shall be developed in the Quality Assurance Plan that shall also prescribe test results and reporting formats. However, some details on the tests are listed tentatively below.

7.11 List Of Tests To Be Conducted Off-Site Tests

(Locations subject to the approval of the Engineer)

S.No.	Description of Tests
1.	UTM Tensile Test for Re-bar
2.	Zinc Coating and Tensile test of GI wire
3.	Los Angeles Abrasion Test for Aggregate
4.	UTM tensile Test for Anchor Bar
5.	Specific Gravity of Aggregates

The tests listed above are subject to the Contractor's Quality Assurance Plan approved by the Engineer. The Engineer shall also determine the number of tests while executing the Works.

The Contractor shall keep records of all tests in a format approved by the Engineer. Two copies of any test results shall be forwarded to the Engineer.

Measurement

Measurement of work under this Clause shall be in number of tests fully executed to the satisfaction of the Engineer.

7.12. Payment

Payment will be made from the Provisional Sum set aside for the purpose and shall be full and final compensation for all material, labor, and equipment to complete the works as specified.

7.13. Survey and Setting

All traverse stations and reference points shall be clearly marked and protected to the satisfaction of the Engineer.

The Contractor shall provide the Engineer with all necessary assistance for checking the setting out, agreement of levels and any other survey or measurement which the Engineer needs to carry out in connection with the Works during the entire period of Contract. Such assistance shall include:

- Provision of suitably qualified surveyors to work under the direction of the Engineer as required.
- Provision of all necessary support for these surveyors including assistants, chainmen, labor, survey equipment (thedolite, levels, etc.), hand tools, pegs, and other incidental material.

The survey equipment shall be of the quality approved by the Engineer.

7.14 Use of the Contractor's Temporary Works

Unless otherwise specified under the Contract, the Contractor shall allow the Employer, the Engineer or the Nominated Subcontractor the use of temporary access, crossings and other Temporary Works at site insofar that such use is related with the Works.

7.15. Day work

Day work shall mean provisional sum payable to the Contractor for works executed on a daily or hourly basis as instructed in writing by the Engineer. This item is categorized in three groups namely:

- (i) Labor
- (ii) Equipment

(iii) Material

The Engineer however shall have the right to obtain further information on the rates and if appropriate to negotiate changes in the rates or demand new prices for additional equipment, staff, or material before or after the award of the Contract.

The Engineer shall have the right to calculate new prices for Day work on the basis of rate analysis.

The hourly or daily rates of labor or equipment and the unit price for material submitted by the Contractor shall deem to cover all expenses and shall be inclusive of overhead, taxes, and profit.

Non-working hours or idle time/down time of labor and equipment respectively shall not be considered for payment.

7.16 Reports

The Contractor shall prepare and submit four copies of Progress Report on a monthly basis. The Reports shall highlight the targeted and achieved progress, problems at site, and brief description of the claims during the month and the Engineer's response, and other information relevant to the Project. It shall be supplemented with necessary charts, tables, data, and at least 36 photographs.

On completion of the Works, the Contractor shall prepare and submit a Completion Report that shall deal comprehensively on all aspects covered in the Monthly Report. Additional information such as improvement in construction methods/techniques, lessons learnt from the Project, important considerations for maintenance, etc. should also be highlighted.

7.17. Site Diary

The Contractor shall keep Site Diaries wherein full details of the work carried out during each day shall be fully recorded. The diaries shall be available for inspection by the Engineer any time during normal office hours. The Site Diaries shall include:

- Weather Conditions, rainfall/snowfall, and river water level
- Description, quantity, and location of work performed
- Shifts and working hours
- Number and category of workers working at site
- Plant in use and idle, or broken down
- Test carried out and results
- Inspection carried out by the Engineer
- Site instructions
- Visitors
- Accidents

7.18 Measurement and Payment

The cost for these works shall be covered by the Contractor's overhead included in unit rates of other items in the BOQ.

5. MATERIALS AND TESTING OF MATERIALS

5.1. Quality Of Materials

The materials supplied and used in the works shall comply with the requirements of these Specifications. They shall be new, except as provided elsewhere in the contract or permitted by the Engineer in writing. The materials shall be manufactured, handled and used skilfully to ensure completed works to comply with the contract.

5.2. Sources Of Materials

The use of any one kind or class of material from more than one source is prohibited, except by written permission of the Engineer. Such permission, if granted, shall set forth the conditions under which the change may be made. The sources or kinds of material shall not be changed without written permission of the Engineer. If the product of any source proves unacceptable, the Contractor shall make necessary arrangements for the supply of acceptable material. Any claims for compensation associated with such arrangements or changes shall not be considered, unless the source of the unacceptable material is designated in the contract as a source of material.

When any manufactured product, either new or used, is to be furnished by the Employer, the location at which such material shall be delivered to the Contractor shall be designated in the contract. In such cases, the Contractor shall haul the materials from the designated delivery point to the point of use. The compensation for such hauling shall be included in the contract unit rate for placing the materials in the finished work.

5.3. Inspection And Acceptance Of Materials

Final inspection and acceptance of materials shall be made only at the site of the work. The Engineer reserves the right to sample, inspect, and test the materials throughout the duration of the works and to reject any materials which are found to be unsatisfactory.

A preliminary inspection of materials may be made at the source for the convenience and accommodation of the Contractor, but the presence of a representative of the Engineer shall not relieve the Contractor of the responsibility of furnishing materials complying with their Specifications.

The representative of the Engineer shall have free entry at all times to those parts of any plant which concern production of the materials ordered.

5.4. Materials And Manufactured Articles

(1) Order for Materials and Manufactured Articles

The Contractor shall, before placing any order for materials and manufactured articles for incorporation in the Works, submit to the Engineer the names of the firms from whom he proposes to obtain such materials and manufactured articles, giving for each firm a description of the materials and manufactured articles to be supplied, their origin, the manufacturer's specification, quality, weight, strength and other relevant details. The Contractor shall submit the samples of such materials and manufactured articles when

requested by the Engineer and when appropriate, manufacturer's certificates of recent test carried out on similar materials and manufactured articles shall also be submitted.

(2) Storage

All materials and manufactured articles shall be stored on site in a manner acceptable to the Engineer. The Contractor shall carefully protect all work, materials and manufactured articles from the weather and vermin.

(3) Test Certificates

When instructed by the Engineer, the Contractor shall submit to him all Test Certificates from the suppliers/manufacturers of the materials and/or manufactured articles to be used for the contract. Such certificates shall certify that the materials and/or manufactured articles concerned have been tested in accordance with the requirements of these Specifications. All Test results shall be enclosed along with such certificates. The Contractor shall provide adequate means of identifying the materials and/or manufactured articles delivered on the site with the corresponding certificates.

5.5. Defective Materials

All materials not conforming to the requirements of the contract shall be rejected whether in place or not. They shall be removed immediately from the site unless otherwise permitted by the Engineer. Even after rectification of the defects no rejected material shall be used in the work unless approved by the Engineer in writing. Upon failure of the Contractor to comply promptly with any order of the Engineer given under this Clause, the Engineer shall have authority to cause the removal and replacement of rejected material and to deduct the cost thereof from any monies due to the Contractor.

5.6. Trade Names And Alternatives

For convenience in designation in the contract, certain articles or materials to be incorporated in the work may be designated under a trade name or the name of a manufacturer and his catalogue information. The use of an alternative article or material which is of equal or better quality and of the required characteristics for the purpose intended shall be permitted, subject to the following requirements:

- (1) The proof as to the quality and suitability of alternatives shall be submitted by the Contractor. He shall also furnish all information necessary as required by the Engineer. The Engineer shall be the sole judge as to the quality and suitability of alternative articles or materials and his decision shall be the final and binding upon the Contractor.
- (2) Whenever the specifications permit the substitution of a similar or equivalent material or article, no tests or action relating to the approval of such substitute material shall be made until the request for substitution is made in writing by the Contractor accompanied by complete data as to the equality of the material or article proposed. Such request shall be made well in advance to permit approval without delaying the work.

5.7. Foreign Materials

Materials which are manufactured, produced or fabricated outside Nepal shall be delivered at a

point in Nepal as specified in the contract where they shall be retained for a sufficient time to permit inspection, sampling, and testing. The Contractor shall not be entitled to an extension of time for acts or events occurring outside Nepal and it shall be the Contractor's responsibility to deliver materials obtained from outside Nepal to the point of delivery in Nepal. The Contractor shall supply the facilities and arrange for testing required at his own cost. All testing by the Contractor shall be subject to witnessing by the Engineer.

The Contractor shall furnish to the Engineer a "Certificate of Compliance" with the specifications from the manufacturer, producer or fabricator of foreign material where required. In addition, certified mill test reports clearly identifiable to the lot of material shall be furnished where required in these Specifications or otherwise requested by the Engineer. Where structural materials requiring mill test reports are obtained from foreign manufacturers, such materials shall be furnished only from those foreign manufacturers who have previously established, to the satisfaction of the Engineer, the sufficiency of their in-plant quality control, as deemed necessary by the Engineer or his representative, to give satisfactory assurance of their ability to furnish material uniformly and consistently in conformance with their Specifications. At the option of the Engineer, such sufficiency shall be established whether by submission of detailed written proof thereof or through in-plant inspection by the Engineer or his representative.

If the welding of steel for structural steel members or the casting and pre-stressing of pre-cast prestressed concrete members is to be performed outside of Nepal, the following requirements shall apply:

- (1) Such fabrication shall be performed only within the plants and by fabricators who have previously established, to the satisfaction of the Engineer, that they have the experience, knowledge, trained manpower, quality control, equipment and other facilities required to produce the quality and quantity of the work required. At the option of the Engineer, prequalification of the plant and fabricator shall be established either by the submission of detailed written proof thereof or through in-plant inspection by the Engineer or his representative, or both.
- (2) The Contractor shall make written application to the Engineer for approval for such foreign fabrication at the earliest possible time and in no case later than 60 calendar days in advance of the planned start of fabrication. The application shall list the specific units or portion of a work which shall be fabricated outside of Nepal.
- (3) The Contractor shall advise the Engineer, in writing, at least 20 calendar days in advance of the actual start of any such foreign fabrication.
- (4) All documents pertaining to the contract, including but not limited to, correspondence, tender documents, working drawings and data shall be written in the English/Nepali language and all numerical data shall use the metric system of units of measurement.

5.8. Definition of General Types of Materials

The following definitions shall apply to materials in this Section and other relevant Sections.

- (1) "Topsoil" shall mean the top layer of soil that can support vegetation. It shall include all turf acceptable for turfing.
- (2) "Suitable Material" shall comprise all that is acceptable in accordance with the contract for

use in the works {and which is capable of being compacted to form a stable fill having side slopes as indicated in the Drawing. The material used in fill (except rock fill) shall not contain rock fragments with dimensions of more than 75 mm.}

- (3) "Unsuitable Material" shall mean other than suitable material and shall include:
- (a) Material from swamps, marshes or bogs;
 - (b) Peat, logs, stumps, perishable material, organic clays;
 - (c) Material susceptible to spontaneous combustion;
 - (d) Material in a frozen condition;
 - (e) Clay of liquid limit exceeding 70 and/or plasticity index exceeding 45.
- Materials stated above in d), if otherwise suitable shall be classified suitable when unfrozen.
- (4) "Well Graded Granular Material" consisting of gravel and/or sand shall conform to relevant Clause.
- (5) "Rock fall", coarse alluvial material shall be loose soils such as moraines, debris, or alluvial material containing large blocks or large boulders. Individual blocks or boulders of hard materials greater than 0.3m³ each in volume, shall be classified as hard material.
- (6) "Hard Material" shall mean any material which conform to the requirements of relevant Sub-clause.

5.9. Sieves

IS sieves shall be used for all tests. Based on IS-460 the standard sieves series shall be as follows:

125; 90; 75; 63; 50; 45; 40; 37.5; 31.5; 25; 22.4; 20; 19; 16; 12.5; 11.2; 10; 9.5; 8; 6.3 ;5.6; 4.75; 4.00; 2.8; 2.36; 2; 1.7; 1.4; 1.18; 1; 0.85; 0.71; 0.6; 0.5; 0.425; 0.400; 0.300; 0.250; 0.212; 0.180; 0.150; 0.125; 0.090; 0.075 mm.

5.10. Soils And Gravels

5.10.1. Sampling and Samples

Sampling of soils and gravels shall be carried out as specified or as directed by the Engineer.

Samples shall be prepared for testing as indicated in IS 2720 part I, except that:

- a) The mass (in g) of a sample required for sieve analysis is about 400D, D being the maximum particle size (mm).
- b) Sample containing particles larger than 19 mm size shall be prepared for compaction and CBR tests as described hereunder, provided the proportion in weight of such particles is less than 30% :

An adequate quantity of representative material shall be sieved over the 50 mm and 19 mm sieve. The material passing the 50 mm sieve and retained on the 19 mm sieve shall be weighed and replaced with an equal mass of material passing the 19 mm sieve and retained on the 4.75 mm sieve. The material for replacement shall be taken from the remaining portion of the main sample. When preparing gravel samples, the aggregations of particles shall be broken with a wooden or rubber hammer or pestle. Care shall be taken that no individual particles are crushed in the operation.

5.10.2. Standard Methods of Testing

Tests on soils and gravels shall be performed in accordance with the standard methods given in Table below:

Tests Procedures Applicable to Disturbed/Undistributed Samples of Soils and Gravels

	Tests		Test procedure
	Determination of:		
i)	Moisture Content	IS 2720	Part 2 (Oven-drying method)
ii)	Liquid Limit	IS 2720	Part 5 (Cone Penetrometer or by Casagrande Apparatus)
iii)	Plastic Limit	IS 2720	Part 5
iv)	Plasticity Index	IS 2720	Part 5
v)	Linear Shrinkage	IS 2720	Part 20
vi)	Specific Gravity of Particles	IS 2720	Part 3
vii)	Particle Size Distribution	IS 2720	Part 4
viii)	Organic Matter Content	IS 2720	Part 22
ix)	Total Sulphate Content	IS 2720	Part 27
x)	pH Value	IS 2720	Part 26 (Electrometric Method)
xi)	Mica Content	-	Manual mineralogical counting
xii)	Density-Moisture Content relationship (2.5 kg rammer)	IS 2720	Part 7
xiii)	Density-Moisture Content relationship (4.9 kg rammer)	IS 2720	Part 8
xiv)	California Bearing Ratio	IS 2720	Part 16
xv)	Sand Equivalent	IS 2720	Part 37 (Mechanical Shaker or Manual Shaker method)
xvi)	Field Dry Density	IS 2720	Part 28/Part 29
xvii)	Unconfined compression test	IS2720	Part 10
xviii)	Consolidation test	IS2720	Part 15
xix)	Direct shear test	1S2720	Part 13
xx)	Triaxial test	IS2720	Part 11,12
xxi)	Hydrometer analysis	IS 2720	Part 4
xxii)	Vane shear test	IS 2720	Part 30

It is further specified that:

- a) Wherever in the text of these Specifications and the Special Specification the term "x% of the MDD (IS 2720 Part 27 or IS 2720 Part 28) is used it shall mean that a standard of compaction shall be achieved such that the dry density of the compacted material is x% of the maximum dry density determined from the respective tests mentioned in Table 6.4. Samples for the compaction tests shall be taken before compaction of the layers begins unless in the opinion of the Engineer the compactive effort proposed or applied by the Contractor is such that the material characteristics have changed in which case the samples for the tests shall be taken after all compaction is complete.
- b) Compaction tests: when the material is susceptible to crushing during compaction, a separate and new sample shall be used in the determination of each point on the moisture/density curve.
- c) The dry density of material placed in the works shall be determined by the Sand Replacement Method unless the Engineer directs to use a nuclear method or other method. In the case of nuclear method, tests shall be done at least at the same frequency required when using the Sand Replacement Method, but at each nuclear densometer test location the average of three readings taken at positions rotated by 90° shall be used. A check/comparison test using the Sand Replacement Method shall be carried out at 10 test interval.

Initial calibration of the nuclear density testing equipment shall be done by carrying out at least fifty tests in parallel with the Sand Replacement Method for each different material encountered. The check tests shall be used to update the initial calibration of the nuclear density testing equipment.

5.11. Stone, Aggregate, Sand And Fillers

(1) Sampling and Preparation of Samples

Sampling shall be carried out as per ASTM-D75 and the samples shall be prepared in accordance with IS 2386 or according to sampling procedures specified for the Standard Methods of testing given in following Table.'

(2) Standards Methods of Testing

Tests on stone, aggregate, sand and filler shall be performed in accordance with the standard procedures given in the following tables.
Tests Procedures Applicable to Stone Aggregate and Fillers'

	Tests	Test Procedure	
	Determination of:		
i)	Particle Size Distribution (Gradation)	IS 2386	Part 1
ii)	Clay, Silt, Dust in Aggregates	IS 2386	Part 2
iii)	Flakiness index	IS 2386	Part
iv)	Specific Gravity	IS 2386	Part 3
v)	Moisture Content	IS 2386	Part 3
vi)	Bulk Density, Voids & Bulking	IS 2386	Part 3
vii)	Soluble Chloride Content	BS812	Part 117
viii)	Mica Content	Manual mineralogical counting	

ix)	Water Absorption	1S2386	Part 3
x)	Crushing Ratio	Manual counting &	weighing
xi)	Los Angeles Abrasion	IS 2386	Part 4
xii)	AIV - ACV	IS 2386	Part 4
xiii)	Polished Stone Value	IS 2386	Part 4
xiv)	Degradability Test	NFP94-067	
xv)	Sodium Sulphate Soundness	IS 2386	Part 5
xvi)	Alkali Aggregate Reactivity Test	IS 2386	Part 7
xvii)	Deleterious Substances	IS 2386	Part 2
xviii)	Sand Equivalent	IS 2720	Part 37
xix)	Crushing Strength of stone	IS 2386	Part 4

5.12. Cement

Ordinary and High Strength Portland Cement (OPC and HSPC), Portland Slag Cement (PSC), Portland Pozzolana Cement (PPC) shall be sampled according to IS 3535 and tested according to IS 4031.

Chemical and physical requirements for Ordinary Portland Cement, High Strength Portland Cement, Portland Slag Cement and Portland Pozzolana Cement shall be in accordance with IS 269, IS 8112, IS 12269, IS 455, IS 1489 respectively.

The requirements on their physical characteristics shall be:

5.12.1. Requirements on the Physical Characteristics of Cement

S.N.	Physical characteristics	OPC/PSC	HSPC	Test Procedure
i)	Fineness, m ² /kg: (by Blaine's Air Permeability method)	225	225	IS-4031 Part 2
ii)	Setting Time:			IS 4031 Part 5
	(a) Minimum Initial Setting Time (minutes)	45	45	
	(b) Maximum Final Setting Time (minutes)	600	600	

iii)	Soundness by Lechatelier method, mm, maximum	10	10	IS 4031 Part 3
iv)	Compressive Strength:			IS 4031 Part 6
	Minimum Average Compressive Strength of three mortar cube(N/mm ²)			
	(a) 3 days	22	27	
	(b) 7 days	29	37	
	(c) 28 days	43	53	

5.13. Lime

Limes shall be sampled and tested in accordance with BS 890 and shall comply with all requirements specified therein.

Lime for treatment shall be Hydrated Calcium Lime or Quicklime and, unless otherwise specified, shall comply with the requirements given in Table below:

5.13.1. Requirements of Lime for Treatment

S. No.	Characteristics	Hydrated lime	Quicklime
i)	Fineness Residue on 0.212 mm sieve - Maximum Residue on 0.075 mm sieve - Maximum	1% 10%	10% 50%
>i)	Chemical requirements Free lime content - Minimum Hydrated lime content - Maximum	50%	60% 5%

5.13.2. Lime Treated Materials

(1) Sampling

Sampling and preparation of samples of lime treated material shall be carried out as specified or as instructed by the Engineer except that:
Samples containing particles larger than 19 mm shall be prepared for compaction and CBR tests. (The fraction coarser than 19 mm shall be replaced by an equal weight of material passing through 19mm sieve and retained on 4.75 sieves).

(2) Standard Methods of Testing

The tests on lime treated materials shall be performed in accordance with the Standard methods:

Additional Tests Procedures Applicable to Lime Treated Materials

Tests	Test Procedure
Determination of: (i) Unconfined Compressive Strength (UCS) (ii) Effect of immersion on UCS (iii) Lime Content	BS1924-Part2 BS 1924 -Part 2 BS 1924-Part 2

5.14. Concrete

Sampling and testing on concrete shall be carried out in accordance with the standard methods given:.

5.14.1. Tests Procedures Applicable to Concrete

S.No.	Tests	Test Procedures
	Determination of:	
(i)	Air contents of fresh concrete	BS 1881-106
(ii)	Density of hardened concrete	BS 1881-114
(iii)	Compressive strength of concrete cubes	BS 1881-116

(iv)	Tensile splitting strength	BS 1881-117
(v)	Flexural strength	BS 1881-118
(vi)	Compressive strength of concrete cores	BS 1881-120
(vii)	Water absorption	BS 1881-122
(viii)	Mixing and sampling fresh concrete in laboratory	BS 1881-125
(ix)	Normal curing of test specimens (20° C method)	BS 1881-111
(x)	Accelerated curing of test specimens	BS 1881-112
(xi)	Making test cubes from fresh concrete	BS 1881-108

5.14.2. Non-destructive Tests Applicable to Concrete

S.No.	Tests	References to Test Procedures
(i)	Method of testing hardened concrete for other than strength	BS 1881-5
(ii)	Guide to the use of non destructive methods of test for hardened concrete	BS 1881-201
(iii)	Recommendation for surface hardened testing by rebound hammer	BS 1881-202
(iv)	Recommendation for measurement of velocity of ultrasonic pulses in concrete	BS 1881-203
(v)	Recommendation on the use of electromagnetic cover meters	BS 1881-204
(vi)	Recommendation for the assessment of concrete Strength by near to surface tests.	BS 1881-207

The test specimens shall be cured at a temperature of 27°C ± 2°C. Water to be used in concrete shall be tested as specified in BS 3148.

The total chloride content, expressed as chloride ion, arising from all ingredients in a mix including cement, water and admixtures shall not exceed the following limits, expressed as a percentage of the weight of cement in the mix :-

For pre-stressed concrete, steam cured concrete or concrete containing sulphate resisting or super-sulphated cement: 0.1 per cent

For any other reinforced concrete : 0.4 per cent

The total sulphate content expressed as SO₃ of all the ingredients in a mix including cement, water and admixtures shall not exceed 0.4 per cent by weight of the aggregates or 4.0 per cent of the weight of the cement in the mix, whichever is the lesser.

5.15. Reinforcing Steel

All reinforcement for use in the Works shall be tested in a Laboratory acceptable to the Engineer and two copies of each test certificate shall be supplied to the Engineer. The sampling and frequency of testing shall be as set out in the NS 84-2042 and NS 191-2045. In addition to the testing requirements described above, the Contractor shall carry out additional testing as instructed by the Engineer.

5.15.1. Testing Of Welds

(1) The tests shall be carried out by the methods described in BS 709. The following

requirements shall also be met with.

(a) General

In any respect the test results of welded joints shall not be inferior to the British Standard test requirements for the parent material.

(b) Procedure Trials

(i) Tensile and Bend Test

Should any one of the weld joint pieces selected for transverse tensile and transverse and longitudinal bend test fail to comply with the requirements applicable to the parent metal of the joint, 2 additional test pieces shall be taken from the joint material represented by the test. Both the test pieces shall comply with the requirements in order to qualify for the acceptance.

(ii) Charpy V-notch Tests

Should the average impact value obtained from any set of 3 Charpy V-notch tests on specimens fail to comply with the requirements, 3 additional test pieces from the same sample shall be tested. The average of the 6 test results shall comply with the test requirements in order to qualify for acceptance.

(iii) Revised Procedures

In the event of failure to meet the requirements, the Contractor shall carry out further trials, using revised procedures, and further tests to the satisfaction of the Engineer.

(c) Production Tests

(i) Tensile and Bend Tests

Should any one of the weld joint test pieces selected for transverse tensile and transverse bend tests fail to comply with the test requirements applicable to parent metal of the joint represented by the test, additional specimens shall be taken from the same production test plates and the test shall be repeated. Should any of the additional tests fail to comply with the requirements, the joint shall be rejected.

(ii) Charpy V-notch Tests

Should the average impact value obtained from any set of 3 Charpy V-notch specimens selected fail to comply with the test requirements, 3 additional test pieces from the same production test plates shall be tested. Should the average of the 6 results fail to comply with the test requirements the joint shall be rejected.

(iii) Re-welding and Re-Testing

In the event of failure to meet the test requirements the welded joint represented by the tests shall be completely cut out. The joint shall then be re-welded and the test repeated.

(iv) Non-destructive Testing

A method of non-destructive testing agreed with the Engineer shall be used for the examination of butt welds in tension members.

5.16. Paints For Structural Steelwork

The Contractor shall submit the proposal to the Engineer about the paint system to be used in the Works.

The system shall be defined at least by the following information, supported by the paint

manufacturer's data sheets:

- Type of system, composition of each component,
- Minimum thickness of each coat,
- Drying time at 10°C and 20°C within a range a relevant hygrometric conditions, including handling conditions, minimum and maximum time of overlap,
- Type of painting method and thinner content, (airless spray, brush, roller etc.)
- Thinner type,
- Blending ratio,
- Maximum time limit of use, by 75% of relative humidity and for a relevant range of temperature and hygrometric conditions,
- Ripening time for a relevant range of temperatures and at least for 20°C and 30°C.
- Weather conditions constraint for painting and drying, including minimum and maximum ambient temperature and temperature of surfaces to be painted.

5.17. Bricks

Bricks shall conform to NS-1-2035 with the exceptions specified

5.18. Mortar

Mortar shall comply with relevant Sub-clause.

5.19. Reinforced Concrete Pipes

Reinforced concrete pipes shall comply with the requirements of NS 80-2042/IS 458:1988.

5.20. Geo textiles

Geo textiles used shall be made of polyethylene or polypropylene or polyester or similar fibres, either woven or non-woven. Unless otherwise shown on the Drawing, the geo textiles shall:

- a) sustain a load of not less than 10 kN/m at break and have a minimum failure strain of 10 percent when determined in accordance with BS: 6906 or shall have a grab tensile strength more than 0.4 kN/m and grab elongation corresponding to this limit in accordance with ASTM D4632.
- b) have apparent opening size as shown on the Drawing. If no size is shown on the Drawing, then the apparent size shall be 0.1 mm.
- c) allow water to flow through it at right angles to its principal plane, in either direction at a rate of not less than 50 liters/sq.m./sec. under a constant head of 100 mm, determined in accordance with BS: 6906 (Part 3) or ASTM D4491, unless otherwise shown on the Drawing. The flow rate determined in the test shall be corrected to that applicable to a temperature of 15°C using data on variation in viscosity of water with temperature
- d) have a minimum puncture resistance of 200 N when determined in accordance with ASTM D 4833.
- e) have a minimum tear resistance of 350 N when determined in accordance with ASTM D 4533. Geo textiles used for drilled sub-surface drains shall be as specified

6. CONCRETE WORK

6.1. Definitions

Structural concrete is any class of concrete which is used in reinforced, pre-stressed or un-reinforced concrete construction which is subject to stress.

Non-structural concrete is composed of materials complying with the Specification but for which no strength requirements are specified and which is used only for filling voids, blinding foundations and similar purposes where it is not subjected to significant stress.

A pour refers to the operation of placing concrete into any mould, bay or formwork, etc. and also to the volume which has to be filled. Pours in vertical succession are referred to as lifts.

6.2. Materials For Concrete

(1) General

The Contractor shall submit to the Engineer full details of all materials which he proposes to use for making concrete. No concrete shall be placed in the works until the Engineer has approved the materials of which it is composed. Approved materials shall not thereafter be altered or substituted by other materials without the consent of the Engineer.

(2) Cement

Cement shall be free flowing and free of lumps. It shall be supplied in the manufacturer's sealed unbroken bags or in bulk. Bagged cement shall be transported in vehicles provided with effective means of ensuring that it is protected from the weather.

Bulk cement shall be transported in vehicles or in containers built and equipped for the purpose.

Cement in bags shall be stored in a suitable weatherproof structure of which the interior shall be dry and well ventilated at all times. The floor shall be raised above the surrounding ground level not less than 30cm and shall be so constructed that no moisture rises through it.

Each delivery of cement in bags shall be stacked together in one place. The bags shall be closely stacked so as to reduce air circulation with min gap of 500mm from outside wall. If pallets are used, they shall be constructed so that bags are not damaged during handling and stacking. Stack of cement bags shall not exceed 8 bags in height. Different types of cement in bags shall be clearly distinguished by visible markings and shall be stored in separate stacks.

Cement from broken bags shall not be used in the works. Cement in bags shall be used in the order in which it is delivered.

Bulk cement shall be stored in weather proof silos which shall bear a clear indication of the type of cement contained in them. Different types of cement shall not be mixed in the same silo.

The Contractor shall provide sufficient storage capacity on site to ensure that his anticipated program of work is not interrupted due to lack of cement.

Cement which has become hardened or lumpy or fails to comply with the Specification in any way shall be removed from the Site.

All cement for any one structure shall be from the same source as far as possible.
 All cement used in the works shall be tested by the manufacturer. The manufacturer shall provide the results of tests as given in following tables for each supply and for the last six months of his production. The Contractor shall supply two copies of each certificate to the Engineer.

6.2.1. Test Results For Chemical Composition Of Cement

Compounds %		Mean	Min	Max.	Standard deviation
Lime	CaO				
Silica	SiO ₂				
Alumina	Al ₂ O ₃				
Iron Oxide	Fe ₂ O ₃				
Magnesia	MgO				
Sulphur Trioxide	So ₃				
Soda, Potash	Na ₂ O, K ₂ O				

6.2.2 Test Results for Physical Properties of Cement

Characteristics	Requirements	Nominal	Mean	Min	Max	St. Dev.
Fineness, M ₂ /KG : (by Blaine's Air Permeability Method)	225					
Minimum Setting time (initial), min	45					
Maximum Setting time (final), min	600					
Soundness (by. Le Chatelie method) mm, maximum	10					
Minimum Compressive Strength of three mortar cubes,						
Average						
(N/mm ²)						
3 days	27*					
7 days	37*					
28 days	53*					

*denotes the requirements of High Strength Portland cement.

Each set of tests carried out by the manufacturer on samples taken from cement which is subsequently delivered to site shall relate to no more than one day's output of each cement plant.

The Contractor shall constitute, from each delivery and each type of cement and not less than one samples for every 200 tons or part of it, representative samples to be tested when instructed by the Engineer in a laboratory acceptable to him, in case of the concrete mixes do not comply with the requirements of this Specification.

Cement which is stored on site for longer than one month shall be tested in such laboratory for every 200 tons or part thereof and at monthly intervals thereafter.

The Contractor shall keep full records of all data relevant to the manufacture, delivery; testing and the cement used in the works and shall provide the Engineer with two copies thereof.

(3) Fine Aggregate

Fine aggregate shall be clean hard and durable and shall be natural sand, crushed gravel sand or crushed rock sand complying with IS 383. All the material shall pass through a 4.75 mm IS sieve and the grading shall be in accordance with IS 383. In order to achieve an acceptable grading, it may be necessary to blend materials from more than one source. The deviation from the initial fineness modulus shall be no more than ± 0.30 for ordinary concrete and ± 0.20 for high quality concrete.

However, in respect of the presence of deleterious materials the fine aggregate shall not contain iron pyrites, iron oxides, mica, shale, coal or other laminar soft or porous materials or organic matter unless the Contractor can show by comparative tests on finished concrete as per the direction of the Engineer, that the presence of such materials does not affect the properties of the concrete.

(4) Coarse Aggregate

Coarse aggregate shall be clean hard and durable crushed rock, crushed gravel or natural gravel corresponding to the following classes:

Class A: Aggregate shall consist of crushed igneous or quartzite rock from an approved source.

Class B: Aggregate shall consist of crushed quarry rock other than Class A from an approved source.

Class C: Aggregate shall consist of natural or partly crushed gravel, pebbles obtained from an approved gravel deposit. It may contain a quantity of material obtained from crushing the oversize stone in the deposit provided such material is uniformly mixed with the natural uncrushed particles.

Class D: Aggregate shall consist entirely of crushed gravel. The crushed gravel shall be produced from material retained on a standard sieve having an opening at least twice as large as the maximum size of aggregate particle specified.

Class E: Aggregate shall consist of an artificial mixture of any of the above classes of aggregate. The use of Class E aggregate and the relative proportions of the constituent materials shall be approved by the Engineer.

Coarse aggregate shall be supplied in the nominal size called for in the contract and shall be of the grading as single sized aggregate or graded aggregate of nominal size 40 mm, 20 mm, 12.5 mm and 10 mm in accordance with IS 383.

Other properties shall be as set out below:

Flakiness Index: When tested in accordance with IS 2386 Part 1, the Flakiness Index of the coarse aggregate shall be as set out hereunder:

For ordinary concrete : not more than 25

For high quality concrete : not more than 15

If the Flakiness Index of the coarse aggregate varies by more than five units from the average value of the aggregate used in the approved trial mix, then a new set of trial mixes shall be carried out if the workability of the mixes has been adversely affected by

such variation.

Water Absorption: The aggregate shall not have water absorption of more than 2 per cent when tested as set out in IS 2386 Part 3.

Los Angeles Abrasion (LAA): The aggregate shall have LAA not more than 45% for ordinary concrete, and not more than 35% for high quality concrete, when tested in accordance with IS 2386 Part 4.

Aggregate Crushing Value (ACV): The aggregate shall have ACV not more than 30% for pavement structure and not more than 45% for other structure when tested in accordance with IS 2386 Part 4.

Alkali Aggregate Reactivity: The aggregate shall comply with IS 383/3.2 notes when tested in accordance with IS 2386 Part 7.

(5) Testing Aggregates

(a) Acceptance Testing

The Contractor shall deliver to the Engineer samples containing not less than 50 kg of any aggregate which he proposed to use in the works and shall supply such further samples as the Engineer may require. Each sample shall be clearly labelled to show its origin and shall be accompanied by all information called for in IS 2386 Part 1 to 8. Tests to determine compliance of the aggregates shall be carried out by the Contractor in a laboratory acceptable to the

Engineer, if the tested materials fail to comply with the Specification, further tests shall be made in the presence of the Contractor and the Engineer. Acceptance of the material shall be based on the results of such tests.

All the materials shall be accepted if the results of not less than three consecutive sets of test executed in accordance with IS 2386 (Part 1-8) show compliance.

b) Compliance Testing/Process Control Testing

The Contractor shall carry out routine testing of aggregates for compliance with the Specification during the period that concrete is being produced for the works. The tests set out below shall be performed on aggregates from each separate source on the basis of one set of tests for each day on which aggregates are delivered to site provided that the set of tests shall represent not more than 100 tons of fine aggregate and not more than

250 tons of coarse aggregate, and provided also that the aggregates are of uniform quality.

Grading: IS 2386 Part 1
Silt, Clay Contents and Organic Impurities: IS 2386 Part 2

If the aggregate from any source is variable, the frequency of testing shall be increased as instructed by the Engineer.

In addition to the above routine tests, the Contractor shall carry out the following tests at the stated frequencies:

Chloride Content: As frequently as may be required to ensure that the proportion of chlorides in the aggregates does not exceed the limit stated in the Specification. Sulphate Content and Alkali Aggregate Reactivity; As frequently as may be required according to the variability of sulphate content and alkali reactivity assessed from the laboratory tests carried out during the concrete mix design.

(6) Delivery and Storage of Aggregates

Aggregates shall be delivered to site in clean and suitable vehicles. Different type or sizes of aggregates shall not be delivered in one vehicle.

Each type or size of aggregate shall be stored in a separate bin or compartment having a base such that the contamination of aggregate is prevented. Dividing walls between bins shall be substantial and continuous so that no mixing of types or sizes occurs.

The storage of aggregates shall be arranged in such a way that drying out in hot weather is prevented in order to avoid sudden fluctuations in water content. Storage of fine aggregates shall be arranged in such way that they can drain sufficiently before use in order to prevent fluctuations in water content of the concrete.

(7) Water for Concrete and Mortar

Water shall be clean and free from harmful matter and shall comply with the requirements of IS 456.

Brackish water containing more than 1000 ppm chloride ion or 2000 ppm sulphate ion shall not be used for mixing or curing concrete.

The Contractor shall carry out tests in compliance with IS 456 to establish compliance with Specifications.

(8) Admixtures

(a) General

The use of admixtures in concrete may be required under the contract to promote special properties in the finished concrete or may be proposed by the Contractor to assist him in compliance with the Specification.

In all cases the Contractor shall submit to the Engineer full details of the admixture he proposes to use and the manner in which he proposes to add it in the mix. The information provided shall include:

- (i) The typical dosage, the method of dosing, and the detrimental effects of an excess or deficiency in the dosage.
- (ii) The chemical names of the main active ingredients in the admixture.
- (iii) Whether or not the admixture contains chlorides, and if so the chloride ion content expressed as a percentage by weight of admixture.
- (iv) Whether the admixture leads to the entrainment of air when used at the manufacturer's recommended dosage, and if so the extent to which it does so.
- (v) Details of previous uses of the admixture in Nepal.

The chloride ion content of any admixture shall not exceed 1 per cent by weight of the admixture nor 0.02 per cent by weight of the cement in the mix.

Admixtures shall not be mixed together without the consent of the Engineer.

Calcium chloride or admixtures containing calcium chloride shall not be used in pre-stressed concrete.

Admixtures may be supplied as liquid or as powder. They shall be stored in sealed and undamaged containers in a dry, cool place. Admixtures shall be dispensed in liquid form and dispensers shall be of sufficient capacity to measure at one time the full quantity required for each batch.

(b) Workability Agents

Workability agents shall comply with BS 5075 and shall not have any adverse effect on the properties of the concrete.

9. The Design Of Concrete Mixes

(1) Classes of Concrete

The classes of structural concrete to be used in the works shall be as shown on the Drawing and designated in following Table, in which the class designation includes two figures. The figures indicates the characteristic strength F_{ck} at 28 days expressed in MPa (N/mm^2) and the second figure is the maximal nominal size of aggregate in the mix expressed in millimetres. Letter M in the class designation stands for Mix, letters SM stand for Special Mix.

Consistence of the mix, assessed through the Slump Test where the slump is measured in millimetres, is designated as follows:

S: Stiff consistence, for slump < 40

P: Plastic consistence, for slump > 40 and < 90

VP: Very Plastic consistence, for slump > 90 and < 150

F: Flowing consistence for slump > 150

9.1. Concrete Classes and Strength

Classes of concrete	Consistence	Type of uses	Characteristic Strength (fck) MPa (N/mm ²)	Maximum Nominal Size of Aggregate (mm)	Trial mixes Minimal Target Strength $f_d=1.1f_{ck}$ MPa (N/mm ²)	Early works test cubes	
						Any one result (aver. of 3 cubes) MPa (N/mm ²)	Average of 3 consecutive results MPa (N/mm ²)
M 10/75	S	Ordinary	10	75	11	10	14
M 10/40	S	Ordinary	10	40	11	10	14
M 15/20	S	Ordinary	15	20	16.5	15	19
M 15/40	S	Ordinary	15	40	16.5	15	19
M 20/20	S	Ordinary	20	20	22	20	24
M 20/40	S	Ordinary	20	40	22	20	24
M 25/20	S	Ordinary	25	20	27.5	25	29
M 25/40	S	Ordinary	25	40	27.5	25	29

(2) Design of Proposed Mixes

Concrete mixes shall comply with relevant Clause.

The Contractor shall design all the concrete mixes called for in the Drawing using the ingredients which have been approved by the Engineer in compliance with the following requirements:

- The aggregate portion shall be well graded from the nominal maximum size of stone down to the 150 micron size.
- The cement content shall be such to achieve the strength called for but in any case not less than the minimum necessary as shown in following Tables
- The workability shall be consistent with ease of placing and proper compaction having regard to the presence of reinforcement and other obstructions.
- The water/cement ratio shall be the minimum consistent with adequate workability but in any case not greater than 0.5 for classes of concrete from M20 to M50 taking due account of any water contained in the aggregates. The Contractor shall take into account that this requirement may in certain cases require the inclusion of a workability agent in the mix.

. Minimum Cement Content

Classes of concrete	Minimum cement content in kg per m concrete of compacted		
	Moderate exposure	Intermediate exposure	Severe exposure
M15/40, M15/20	150	200	225
M20/40, M20/20	250	300	325
M25/20, M25/40	300	325	350

Note: The minimum cement contents shown in the above table are required in order to achieve impermeability and durability. In order to meet the strength requirements in the Specification higher contents may be required.

The categories applicable to the works are based on the factors listed hereunder:

- Moderate exposure : Surface sheltered from severe rain, buried concrete.
 Intermediate exposure : Surface exposed to severe rain; alternate wetting and drying; traffic; corrosive fumes; heavy condensation.
 Severe exposure : Surface exposed to water having a pH of 4.5 or less, groundwater containing sulphate.

(3) Laboratory Trial Mixes

For each mix of concrete for which the Contractor has proposed a design, he shall prepare the number of concrete batches specified hereunder:

Nominal composition : 3 separate batches

Modified compositions, the quantities of other constituents being unchanged:

- Water : +10% 1 batch
 Water : -10% 1 batch
 Cement : +15% 1 batch
 Cement : -15% 1 batch

Samples shall be taken from each batch and the following action taken, all in accordance with BS 1881:

- (a) The slump of the concrete shall be determined.
- (b) Six tests cubes shall be cast from each batch. In the case of concrete having a maximum aggregate size of 20 mm, 150 mm cubes shall be used. In the case of concrete containing larger aggregate, 200 mm cubes shall be used and in addition any pieces of aggregate retained on a 50 mm IS sieve shall be removed from the mixed concrete before casting the cubes.
- (c) The density of all the cubes shall be determined before the strength tests are carried out.
- (d) All faces shall be perpendicular to each other.
- (e) Three cubes from each batch shall be tested for compressive strength at seven days and the remaining three at 28 days.

For "Smaller Contracts works", the following compositions are suggested as a starting basis for the Laboratory trials for one m3 of concrete:

Concrete Class	Characteristic Strength N/mm	Cement (kg)	Total aggregates (kg)	Fine aggr./ Total Aggr. (%)	Water (max) (lit.)	Workability
M 15/40-1	15	250 300	1900	35-45	160	Stiff-
M 15/20	20		1875	35-45	165-	Plastic
M 20/20					170	Stiff

A "result" being the average strength of the three cubes from one batch, the average of the three results from tests at 28 days for the nominal composition shall not be less than the Minimal Target Strength shown in the Table.

One result from the modified compositions shall not be less than the nominal strength as shown on Table above.

(4) Site Trials

At least six weeks before commencing placement of concrete in the permanent works, site trials shall be prepared for each class of concrete specified.

For each mix of concrete for which the Contractor has proposed a design and successfully tested in Laboratory , he shall prepare three separate batches specified hereunder using the materials which have been approved for use in the works and the mixing plant which he proposes to use for the works. The volume of each batch shall be the capacity of the concrete mixer proposed for full production.

Samples shall be taken from each batch and the action taken. The average of the three results of tests at 28 days shall not be less than the Minimal Target Strength.

The Contractor shall also carry out tests to determine the drying shrinkage of the concrete unless otherwise directed by the Engineer.

Based on the results of the tests on the Laboratory trial and site trial mixes, the Contractor shall submit full details of his proposals for mix design to the Engineer, including the type and source of each ingredient, and the results of the tests on the trial mixes.

If the Engineer does not agree to a proposed concrete mix for any reason, the Contractor shall amend his proposals and carry out further trial mixes. No mix shall be used in the works without the written consent of the Engineer.

(5) Quality Control of Concrete Production

(a) Sampling

For each class of concrete in production at each plant for use in the works, samples of concrete shall be taken at the point of mixing or of deposition as instructed by the Engineer, all in accordance with the sampling procedures described in BS 1881 and with the further requirements set out below.

Six 150 mm or 200 mm cubes as appropriate shall be made from each sample and shall be cured and tested in accordance with BS 1881 three at seven days and the other three at 28 days. Where information samples are required, such as for post-tensioning operations, three additional cubes shall be made.

The minimum frequency of sampling of concrete of each grade shall be as following:

For 1-5 m ³ quantity of work	-	1 no. of sample	
For 5-20 m ³ quantity of work	-	2 no. of sample	
For 20 m ³ and more quantity of work	-	3 no. of sample plus one additional	for each 20m ³ or part thereof.

At least one sample shall be taken from each shifts of work.

Until compliance with the Specification has been established the frequency of sampling shall be three times that stated above and not less than 3 samples/day for each class of concrete in production at each plant or such lower frequency as may be instructed by the Engineer.

(b) Testing

(i) The slump of the concrete shall be determined for each batch from which samples are taken and in addition for other batches at the point of production and deposition or at the frequency instructed by the Engineer. The slump of concrete in any batch shall not differ from the value established by the trial mixes by more than 25 mm or one third of the value whichever is the less.

(ii) The air content of air entrained concrete in any batch shall be within 1.5 times of the required value and the average value of four consecutive measurements shall be

within the required value expressed as a percentage of the volume of freshly mixed concrete.

- (iii) Early Works: Until such time as sufficient test results are available to apply the method of control described in (iv) below, the compressive strength of the concrete at 28 days shall be such that no single result (average of 3 cubes) is less than the characteristic strength f_{ck} as shown in Table under the Heading "early works test cubes" and also that the average of three consecutive results is not less than $f_{ck} + 4$ as shown in Table under the same heading.

The 7-day cube result may be used as an early strength indicator, at the discretion of the Engineer.

- (iv) When at least 20 consecutive results on tested batches are available for any class of concrete mixed in any one plant, no single result shall be less than $f_{ck} + 4$ (N/mm²) and also the average of any group of three consecutive results shall not be less than $f_{ck} + 4$ (N/mm²).

In addition the Coefficient of Variation shall be less than the figure given below:

Number of batches	Maximum coefficient of variation	
	Ordinary concrete	High quality concrete
After 20 tested batches	18%	15%
After 50 tested batches	15%	12%

Where the Coefficient of Variation = (Standard Deviation of the results/Average value of the result)

- (v) Failure to comply with Requirements:

If any one result in a group of three consecutive results is less than $f_{ck} - 4$ (N/mm²), but the other results of group satisfy the strength requirement, then only the batch from which the failed result was obtained shall be deemed not to comply with the Specification.

If the average strength of the group is less than the strength requirement then all the batches between those represented by the first and the last result shall be deemed not to comply with the Specification, and the Contractor shall immediately adjust the production procedure or the mix design subject to the agreement of the Engineer to restore compliance with the Specification.

The Contractor shall take necessary action to remedy concrete which does not comply with this Specification. Such action may include but not necessarily confined to the following :

- Increasing the frequency of sampling until control is again established.
- Carrying out non destructive testing such as ultrasonic measurements, load tests or other appropriate methods,
- Cutting test cores from the concrete and testing in accordance with BS 1881
- Carrying out strengthening or other remedial work to the concrete where possible or appropriate.
- Removing the concrete.
- Accepting as sub standard

7. WOOD WORK

7.1. Quality:

Generally the timber shall be Sal wood unless otherwise stated of the best quality obtained from an approved saw mill. Timber for carpentry shall be straight and free from twist, sapwood, shakes, dead and loose knots, worm holes, other holes, signs of decay and other defects, and seasoned and shall comply with the requirements of IS 883-1994

The minimum compressive strength of the timber shall be 70 kg/cm².

7.2. Kind:

The timber shall be best quality timber as specified in the item. The samples of the approved timber to be used shall be deposited in the office of Engineer for the purpose of comparison.

Colour:

The Colour shall be uniform as far as possible, the darkness of colour amongst colour species of timber being generally a sign of strength and durability.

Moisture:

The natural moisture content of any untreated timber delivered to site shall not exceed those as recommended by IS 287-1993. All timber shall be seasoned to moisture content of not more than 22% for frames and 15% for shutter. The contractor's price must include for any kiln drying that may be necessary to achieve these figures

Stacking:

As soon as the foundation of building are laid all necessary timber, scantling shall be brought to the site and stacked as laid down in IS 401 - 1967 till required. All timber of assembled woodwork shall be protected from the weather and stored in such a way as to prevent attack by termites, insects or decay fungi for which temporary shed shall be built. All timber shall be stored at least 750mm above ground level or more, if deemed necessary and individual members shall be separated by strips so that air may circulate around all four sides.

Timber for the work shall not be brought to the site of work until the sample and approved by the Engineer who may reject the defective timber/timber works. Any effort like plugging, painting, using any adhesive or resinous material to hide defect shall render the pieces, rejectable by the Engineer. Timber presented for inspection shall clean and free from dust, mud, paint or other material, which may conceal the defects. Cut-off ends for protection can be done after inspection with raw linseed oil or any other materials approved by the Engineer. No timber be painted, tarred or oiled primed without the previous permission of the Engineer.

7.3. Sawing:

All beams and scantling shall be sawed straight lines, planes and of uniform thickness with full measurement from end to end and shall be swan along grain and under no condition beams, rafters, wall plates, blocks etc. shall be sawed across grain. They shall be sawn with such sufficient margin as to secure specified dimensions, lines and planes after being brought and

dressed.

All wood work except door/window frames or ceiling shall be painted with two coats of creosote conforming to IS 218 1952. Any timber rejected shall at once be removed from the site. The contractor shall be responsible up to the end of the maintenance period for executing at his own cost all work necessary to eradicate insect attack of timber which becomes evident, including the replacement of timber attached or suspected of being attacked, not with standing that the timber concerned may have already been inspected and passed as fit to use before.

7.4. Hardware

Hardware shall consist of bolts, with the necessary nuts and washers, timber connectors, drift pins, dowels, nails, screw nails, coach bolts, spikes and other metal fasteners. They shall be galvanized or un-galvanized as specified. Bolts, nuts and washers shall be mild steel and comply with IS 1363-1992. Drift Pins and dowels shall be mild steel. Nails shall comply with IS 723-1972. Screw nails and screws shall comply with IS 451-1972/IS 2585-1968. Coach bolts shall comply with IS 2609-1972. Spikes and other metal fastenings shall be of mild steel.

7.5. Holdfast

All panels except where specified in the drawing shall be fitted with frames having steel double breasted butt hinges. Window frames shall have three 7.5cm / 2.00 mm thick hinges on each panel whereas the size of hinges for door panels shall be as follows:

Width of panels (up to 75cm) : 10cm double breasted butt hinge, 2.00mm thick, 3 nos.

Width of panels exceeding 75cm : 12.5cm double breasts butt hinges, 2.25mm thick, 3 nos.

Following shall be the size of the screw:

For 7.5cm hinges : 25mm long No. 8

For 10cm hinges : 30mm long No. 9

For 12.5cm hinges : 45mm long No. 10

Above No. refers to Nettlefolds or equivalent screws only.

Doors shall be fitted with double-action automatic hydraulic door closers wherever instructed.

7.6. Tower Bolt

All tower bolts shall be of aluminum with bolt casted monolithic with the handle. Following shall be size of the tower bolt.

Windows Panels 15cm top and bottom

Door 15cm top

15cm bottom (wherever necessary)

All screws shall be of Nettlefold or equivalent suitable lengths and diameter.

7.7. Handles

All doors shall be provided with handle on both sides and all windows with handles on the inner side only. Door handled shall be minimum 15cm clear inside and window handle 10cm clear.

All doors shall be fitted with mortise lock of heavy quality, preferably of aluminum.

Note

A sample of hardware (tower bolts, handles, hinges, catch and allotrope and screws) will be displayed at the site at Project Engineer's office as the sample of desired quality and design. The Contractor shall submit samples of hardware in writing to Project Engineer for approval.

7.8. Construction

When ventilator is provided above the door, full length, of the vertical post shall be provided. Joints in the frame vertical style or horizontal rail shall not be allowed. The unrelated edges of the frame in the opening shall be rounded or beaded uniformly.

The rebate and the plaster key grooves shall be provided as shown in the drawing. Vertical part of the frame shall be embedded at least 30 mm in the masonry or concrete or flooring. Hold fasts shall be provide as specified and any adjustment of spacing necessary shall be erected in position and held in plumb with proper supports from both sides and built in masonry as it is being built.

The Work shall be as per the drawing. the timber shall be properly planned wrought and dressed in a workmanship manner.

All joinery work shall be securely mortised and tenoned and glued with best quality waterproof glue. All sections and dimensions are to be as shown on drawings. For all joinery work, use of nails shall not be permitted. Wood screws of appropriate size and of approved make shall be used. Wherever practicable, means of fastening the various parts together shall be concealed. All work (both carpentry and joinery) shall be to the dimensions shown on the drawings.

The rate of woodwork shall include the cost of all sawing, planning, joining, bolts, nails, spikes, keys wedges, pins, screw etc. necessary for the framing and fixing. Joints and portions inserted in masonry or floor shall be allowed for in the measurement. Plugging in of holes for hold fasts shall be done in neat manner. Any defects observed after installation shall be rejected. Sample of workmanship shall be submitted for approval.

7.9. Timber Preservation

When described in the contract or shown on the Drawing timber shall be treated with preservative in accordance with the Indian Standard Code of Practice for the preservation of timber IS 401-1982.

7.10. Insect Damage

All timber shall be free from live barer beetle or other insect attack when brought upon the Site. The Contractor shall be responsible to the end of the maintenance period for executing at his own cost all Work necessary to eradicate insect attack of timber which becomes evident, including the replacement of timber attacked or suspected of being attacked, not with standing that the timber concerned may have already been inspected and passed as fit for use.

7.11. Seasoning of Timber

All timber shall be seasoned to a moisture content of not more than 22% for carpentry and 15% for joinery. The Contractor's price must include for any kiln drying that may be necessary to achieve these figures.

7.12. Inspection and Testing

The Project Engineer shall be given facilities for inspection of all works in progress whether in Workshop or on Site. All timber as it arrives on the Site and not approved by them must be removed forthwith, failing which the Employer, with the advise of the Project Engineer, may arrange for the removal of the rejects and impose of them as they may consider advisable at the Contractor's expenses.

Notwithstanding approval having been given as above, any timber incorporated in the Works found to be in any way defective before the expiry of the maintenance period shall be removed and renewed at the Contractor's expense. The Contractor is to allow for testing or prototypes of special construction units and the Project Engineer shall be at liberty to select any samples they may require for the purpose of testing i.e. for moisture content, or identification of species, strength, etc. Where timbers need to be extended into a wall, they shall be thoroughly "Brush Treated" with a wood preservative approved by the Project Engineer, and as much clear air space maintained around the timber where it adjoins the wall as possible.

7.13. Clearing Up

The Contractor is to clear out and destroy or remove all cut and shavings and other wood waste from all parts of the building and the Site generally, as the work progress and at the conclusion of the work.

7.14. Galvanizing

When described in the contract or shown on the Drawing, all hardware shall be galvanized in accordance with the Indian Standard Recommended Practice for Hot-Dip Galvanizing of Iron

7.15. Carpentry and Joinery

7.15.1. Carpentry

All carpentry shall be executed with workmanship of the best quality. Scantlings and boarding shall be accurately sawn and shall be of uniform width and thickness throughout. All carpenter's work shall be left with sawn surface except where particularly specified to be wrought.

All carpenter's work shall be accurately set out in strict accordance with the drawings and shall be framed together and securely fixed in best possible manner with properly made joints. All necessary brads, nails and screws, etc. shall be provided as directed and approved.

Actual dimensions of scantlings for carpentry shall not vary from the specified dimensions by more than 3mm in deficiency or excess but must be uniform throughout. Boards 25mm thick or less shall hold up to the specified sizes. All timbers shall be as long as possible and practicable, in order to eliminate joints.

7.15.2. Joinery

Generally all joiner's work shall be accurately set out on boards to full size for the information and guidance of the artisans before commencing the respective works, with all joints, iron work and

other works connected therewith fully delineated. Such setting out must be submitted to the Project Engineer and approved before such respective works are commenced.

All jointer's work shall be cut out and framed together as soon after the commencement of the building as is practicable, but is not to be wedged up or glued until the building is ready for fixing same. Any portions that warp wind or develop shakes or other defects within twelve months after completion of the works shall be removed and new fixed in their place on Contractor's own expense.

All work shall be properly mortised, tenoned, housed, shouldered, dovetailed, notched, wedged, pinned, braided, etc., as directed and to the satisfaction of the Project Engineer and all properly glued up with the best quality approved glue.

Joints in joinery must be as specified or detailed, and so designed and secured as to resist or compensate for any stresses to which they may be subjected. All nails, springs, etc. are to be punched and puttied. Loose joints are to be made where provision must be made for shrinkage, glued joints where shrinkage need not be considered and where sealed joints are required. Glue for load-bearing joints or where there is damp conditions must be of the resin type. For non-load-bearing joints or where dry conditions may be guaranteed casein or organic glues may be used.

Where Joinery work is specified to be built in, it shall be the responsibility of the contractor to ensure that the joinery works are set to plumb and true and shall not be damaged or displaced by subsequent operations. The contractor shall also provide and secure suitable anchors or other fixings as per drawings and details. All exposed surfaces of joinery Work shall be wrought and all arises "eased-off" by planing and sand papering to an approved finish suitable to the specified treatment.

Dimensions

Joinery shall hold up to the specified sizes and as measured.

7.15.3. Fixing Joinery

All beads, fillets and small members shall be fixed with round or oval brads on nails on nails well punched in and stopped. All large members shall be fixed with screws; the heads let in and palliated to match the grain. Unless otherwise specified, plugs of external work shall be of hardwood, plugs for internal work may be of softwood. Holes for plugging must be made with a proper drilling tool and the holes completely filled with the plugging material.

Unless otherwise specified all skirting, window, grounds and backings for same, fillets etc. shall be plugged at intervals not exceeding 60cm.

7.15.4. Budding Joiner

All door and window frames, sills, wooden bars etc., which are fixed to brickwork, concrete by means of grounds, lugs, etc., shall be bedded solid in mortar as previously described and pointed with a recessed joint 6mm deep to the approval of the Project Engineer.

Plywood's, Blackboards, Chipboards etc., shall be of a standard quality. They shall be bonded with synthetic resin or "interior" type unless otherwise stated. Where stated to be "exterior" type, they shall be weatherproof. All exposed edges of blackboard and clipboard shall be lipped with hardwood as described below.

Samples of all such materials and their source of manufacture must be approved by the Project Engineer before used in the works.

7.16. Plastic Sheeting

Shall be approved laminated sheeting 1.5mm thick, securely fixed by means of Aerodux 185 adhesive, and in colours approved by the Project Engineer.

7.17. Ironmongery

All locks and Ironmongery shall be fixed with screws, etc., to match. Before the woodwork is painted, handles shall be removed, carefully stored and re-fixed after completion of painting and locks oiled and left in perfect working order.

Prices for fixing locks must include for organizing master-keying systems if required and all keys shall be labeled with door references marked on approved labels before handing the Project Engineer on completion.

7.18. Protection of Work

The contractor shall be responsible for the temporary doors and closing in openings necessary for the protection of the work during progress. He shall also provide and maintain any other temporary covering required for the protection of finished woodwork that may be damaged during the progress of the work if left unprotected.

8. DETAILED SPECIFICATIONS OF BUILDING WORKS (CIVIL)

Item	Particulars	Detailed Specification
A. Site Preparation Works		
	General	<p>All material from site clearance shall be the property of the Employer and depending on its nature shall, as directed by the Engineer, be either</p> <ol style="list-style-type: none"> Stockpiled for future reuse. disposed by controlled burning. disposed by tipping or side casting with all lift within 30m. <p>Topsoil, referred to in this Clause shall mean the top 100 mm layer of soil with roots and organic matter, which is capable of vegetation support.</p> <p>Measurement Clearing and grubbing executed as per this Specification shall be measured in square meter.</p> <p>Cutting trees including removal of stumps and their roots and backfilling to required compaction shall be measured in number. For this purpose, girth shall be measured at a height 1 meter above ground.</p> <p>Cutting of trees up to 300 mm girth including removal of stumps and roots and backfilling of holes with compaction shall not be measured separately.</p> <p>Payment Clearing and grubbing and cutting trees shall be paid at their respective contract unit rates which shall be the full and the final compensation to the Contractor. The contract unit rate for cutting of trees of girth above 300 mm shall also include handling, salvaging, piling and disposing off the cleared materials with all leads and lifts.</p>
A1	Tree cutting	<p>The Contractor shall take the necessary precautions to prevent damage to structures and other private or public property. If necessary, trees shall be cut in sections from the top downwards. The branches of trees to be left standing shall be trimmed so as not to intrude into a space of 7 m above the roadway.</p> <p>Such individual trees as the Engineer may designate and mark in white paint shall be left standing and uninjured. In order to minimize damage to trees that are to be left standing, trees shall be felled towards the center of the area being cleared, if so required by the Engineer.</p> <p>Permission for cutting trees must be obtained from the competent authority that may require that trees be numbered, measured and marked in the presence of officials from that authority. Cutting of such trees shall then be carried out by the Contractor and the timber stored at designated locations within the Right of Way.</p> <p>Felling and cutting of trees on the site and piling them off the site shall conform to the requirements of the competent authority.</p> <p>All tree trunks and branches in excess of 150 mm in diameter shall be cleaned off, secondary branches cut into suitable length and</p>

		<p>stacked at sites indicated by the Engineer. Such timber shall not be used by the Contractor for any purpose and shall remain the property of the Employer.</p> <p>All timber except such timber as can be used and all brush, stumps, roots, rotten wood and other refuse from the clearing and grubbing operations shall be completely removed from within the Right of Way.</p> <p>Where directed by the Engineer, the area covered by anthills shall be treated, after excavation and before backfilling of cavities, with an approved ant control chemical.</p>
A2	Removal of roots	<p>In the site all trees up to 300 mm girth, stumps and roots shall be removed to a depth of not less than 900 mm below the finished level and a minimum of 500 mm below the original ground level whichever is lower.</p> <p>Except in borrow areas the cavities resulting from the grubbing shall be backfilled with approved material and compacted to a density not less than the density of the surrounding ground.</p>
A3	Site cleaning	<p>Clearing shall consist of the cutting, removing and disposal of all trees, bushes, shrubs, grass, weeds, other vegetation, anthills, rubbish, fences, top organic soil not exceeding 150 mm in thickness and all other objectionable material, resulting from the clearing and grubbing. It shall also include the removal and disposal of structures that obstruct, encroach upon or otherwise obstruct the work.</p> <p>The moving of a certain amount of soil or gravel material may be inherent to or unavoidable during the process of clearing and no extra payment shall be made for this. Clearing shall include the removal of all rocks and boulders of up to 0.15 m³ in size exposed or lying on the surface.</p>
A4	Surface dressing	<p>Conservation of Top Soil</p> <p>Where suitable topsoil exists within the limits of the area to be cleared and grubbed, the Contractor shall, if ordered by the Engineer, remove the topsoil together with any grass and other suitable vegetation. If not used immediately, the topsoil shall be transported and deposited in stockpiles for later use.</p> <p>Conservation of Flora</p> <p>Where provided for in the contract, certain designated flora encountered in the road reserve and borrow areas shall be carefully protected by the Contractor. In his tendered rate for Site Clearance, he shall include for the careful removal and planting of the flora in a protected and fenced-off area and, on completion of the road, for the replanting of the flora in suitable positions in the road reserve in accordance with the Engineer's instructions.</p> <p>Execution of Work</p> <p>Stumps, embedded logs, roots and all other vegetation growth and accumulated rubbish of whatsoever nature and all other objectionable material shall be completely removed to a specified depth.</p> <p>Normally the portions of the road reserve that fall within the limits of the road prism, as well as certain borrow areas shall be cleared and/or grubbed. Where the road reserve is to remain unfenced, the full width of the road reserve shall be cleared and/or grubbed except for such trees designated by the Engineer to be left standing and uninjured.</p> <p>The Contractor shall mark the boundaries of the area for clearing and grubbing and seek the approval of the Engineer before commencement of the work. The Engineer shall designate in detail the exact areas to be cleared and grubbed and the time at which it shall be done.</p>

		<p>Disposal of Material Material obtained from clearing and grubbing shall be disposed off in borrow pits or other suitable places and be covered up with soil or gravel as directed by the Engineer. The burning of combustible material shall not, normally, be permitted and may only be done with the prior written approval of the Engineer. Where fences have to be taken down, fencing wire shall be neatly wound into reels and all such wire, together with all fence posts and other serviceable material from structures, etc., shall be stacked at sites indicated by the Engineer.</p> <p>Re-clearing of Vegetation When portions of the road reserve, borrow or other areas have been cleared in accordance with the Specifications, but in the course of time, vegetation grows again during construction, the Engineer may, if he considers it necessary, order that the area be re-cleared. Before the bottom layer of the embankment is made, the Contractor shall grub up and remove any vegetation that may in the meantime have grown on the surfaces previously cleared and grubbed. Such re-clearing of areas previously cleared includes the removal and disposal of grass, shrubs and other vegetation in the same manner as for the first clearing operation. No separate payment shall be made for re-clearing of vegetation.</p>
A5	Turfing	<p>The area from where the grass roots are to be obtained shall be specified by the Engineer-in-Charge at the time of execution of the work and no royalty shall be charged on this account from the contractor. The soil shall be suitably moistened and then the operation of planting grass shall be commenced. The grass shall be dibbled at 10 cm, 7.5 cm, 5 cm apart in any direction or other spacing as described in the item. Dead grass and weeded shall not be planted. The contractor shall be responsible for watering and maintenance of levels and the lawn for 30 days or till the grass forms a thick lawn free from weeded and fit for moving whichever is later. Generally planting in other direction at 15 cm, 10 cm, spacing is done in the case of large open spaces, at 7.5 cm spacing in residential lawn and at 5cm spacing for Tennis Court and sports ground lawn. During the maintenance period, any irregularities arising in ground levels due to watering or due to trampling by labor, or due to cattle straying thereon, shall be constantly made up to the proper levels with earth as available or brought from outside as necessary, Constant watch shall be maintained to ensure that dead patches are replanted and weeds are removed.</p> <p>Measurements Length, breadth of the lawn grassed shall be measured and the area shall be calculated in sqm. correct to two places of decimal.</p> <p>Rate The rate shall include of all the labor and material involved in all the operations described above.</p>

A6	Tree planting inclusive tree guards	<p>In ordinary soil, including refilling earth after mixing with oil cake, manure and watering. Holes of circular shape in ordinary soil shall be excavated to the dimensions described in the items and excavate soil broken to clods of size not exceeding 75 mm in any direction, shall be stacked outside the hole, stones, brick bats, unsuitable earth and other rubbish, all roots and other undesirable growth met with during excavation shall be separated out and unserviceable material removed from the size as directed. Useful material, if any, shall be stacked properly and separately. Good earth in quantities as required to replace such discarded stuff shall be brought and stacked at site by the contractor.</p> <p>The tree holes shall be manured with powdered Neam/castor oil cake at the specified rate along with farm yard manure over sludge shall be uniformly mixed with the excavated soil after the manure has been broken down to powder, (size of particle not be exceeded 6 mm in any direction) in the specified proportion, the mixture shall be filled in to the hole up to the level of adjoining ground and then profusely watered and enable the soil to subside the refilled soil shall then be dressed evenly with its surface about 50 to 75 mm below the adjoining ground level or as directed by the Engineer-in-charge.</p> <p>Tree Guard The tree guard shall be 450 mm in diameter and 1 meter high above ground level and 25 cm in below ground level. The tree guard shall be framed of 4 nos. 20 x 3 mm MS. Flat welded to 50x50 wire mesh. The entire tree guard shall be given two coats of synthetic enamel paint of approved brand and manufacturer of required shade brand and manufacturer of required shade over a priming coat of ready mixed steel primer of approved brand and manufacturer.</p> <p>Measurement : The tree guard shall be enumerated. Rate: The rate shall include the cost of all the labor and material involved in all the operations described above.</p>
A7	Soil Investigation	<p>The job includes the activities like soil investigation works, bore hole of required depth including mobilization and demobilization of drilling machines (Rotary or percussion), Field test (SPT, Field density test, vane shear test), lab test (consolidation, direct shear test, unconfined compression test, chemical test ,specific gravity test, sieve analysis, moisture content, Atterberg's limits tests etc.) and preparation of soil analysis report</p>
B. Soil and Sand Works		
B1, B7	Excavation	<p>Foundation trench shall be dug to the exact width and depth and levels as indicated in the drawings or to such lesser or greater extent as the Engineer may advice. Sides of trenches shall be vertical. In case the soil does not permit vertical sides, the Contractor shall protect side with timber shoring. Excavated earth shall not be placed within 1.5 meter of the edge of the trench. The Project Engineer may direct the Contractor to place excavated earth</p>

		<p>at a particular site up to 30 meter away from the building. The bottom of the trench shall be perfectly levelled both longitudinally and transversely. The bed shall be lightly watered and well-rammed. Excess digging if done through mistake shall be filled with 1:4:8 concrete. Water, if any accumulated in the trench, shall be bailed out and all necessary precaution taken to prevent surface water from entering the trench. Soft and defective spot in the trench shall be dug out and removed and filled with concrete or materials prescribed by the Project Engineer. If rocks or boulders are found during excavation, they should be removed and the bed trench shall be levelled and made hard by consolidating the earth, at no extra cost. Above mentioned items or any variation thereof from the Bills of Quantities shall be measured and valued by the Engineer as a variation. After the completion of foundation masonry, the remaining portion of the trench not filled by masonry shall be filled up with earth in layers of 15cm, watered and well-rammed. Such filling shall be free from rubbish, refuse matters and clods, surplus earth, if any shall be removed and site shall be levelled and dressed.</p> <p>Trenches shall be measured as per drawings and rate shall be for complete Work including trench filling, for 30 meter lead and 1.5 meter lift including all tools and plants required for the completion of the work, removal of boulders, side shoring, pumping, and filling in voids by mass concrete (1:4:8).</p> <p>No excavation or foundation work shall be filled in or covered up before the inspection and approval of the Project Engineer.</p> <p>The starting level for excavation shall be deemed to be ground level or such level as may be specified by the Project Engineer, before the commencement of the Work.</p> <p>Measurement</p> <p>Measurement of all works will be made in m³.</p> <p>Measurement for payment under the contract will be limited to the lines, grades, slopes and dimensions shown on the Drawings or as determined by the Engineer as the work proceeds on the basis of his evaluation of the soil/rock characteristics and site-conditions set forth in the Clause.</p> <p>All required and accepted excavation shall be measured from its original position. The volume shall be determined in cubic meters by average area method to be computed from the original and final cross-sections of the completed works as per the drawings or as directed by the Engineer. Where it is not practicable to use the above method of measurement, the Engineer may use volumetric method or any other method that in his opinion is best suited for accurate assessment.</p> <p>Any over-excavation shall be reinstated at the risk and cost of the Contractor as directed by the Engineer.</p> <p>Payment</p> <p>Payment for work under these clauses will be made on the basis of contract unit price indicated in the BOQ.</p> <p>The payment will be full and final compensation for all material, labor, and equipment to complete the works as specified.</p>
--	--	--

<p>B2,B3 B5,B6</p>	<p>Backfill</p>	<p>This work is related to all types of structures that require filling with specified material in the remaining volume or space of excavation left unoccupied by any permanent construction.</p> <p>Activities involved are collection and transportation of suitable material from local borrow pits or hill side excavation, placing the specified backfill material in layers, removal of foreign material if any, watering, compacting to required density, lines and levels as indicated in the drawings or as directed by the Engineer.</p> <p>Compaction shall proceed after the Contractor together with the Engineer identify the optimum thickness of each layer of suitable material, its optimum moisture content, and the corresponding number of passes required for a roller to arrive at the corresponding OMC. Prior to the start of works, the contractor shall prepare a trial stretch to establish the above parameters and shall repeat it as often as necessary due to change in layer thickness, borrow pits, and /or change in equipment. The Contractor may use the Standard Specifications for Roads and Bridge Works of GON, MWOT, DOR as guide for the above purpose.</p> <p>Backfill, classified according to their nature, are presented in the following Sub-Clauses.</p> <p>Backfill in Plinth of Building and Parking</p> <p>This work shall consist of filling for construction of embankment for plinth of building, road works and parking area and includes furnishing, placing, watering, compacting and shaping suitable material obtained from approved sources in accordance to lines, levels, grades, dimensions shown on the Drawings and or as required by the Engineer. Fill material used shall not exceed 150 mm and 75 mm within the 300 mm and 150 mm of formation level respectively. Fill material shall not have organic content value exceeding 5% and soaked CBR value less than 6% unless otherwise approved by the Engineer.</p> <p>Activities involved shall be preparation of surface, scarifying, supply, and laying of suitable material in layers. Except where material is laid close to the formation level, each layer shall not exceed 300 mm in thickness before compaction. Each layer of material shall then be watered and compacted to 95% dry density at optimum moisture content. Testing shall be carried out by sand cone using relevant BS or ASTM Standards.</p> <p>The top level of such fill executed shall be regarded as the formation level.</p> <p>Common Backfill In Structures</p> <p>Common backfill includes stacked suitable material recovered from excavations or material transported from outside. This may include granular material passing through 75 mm sieve or sandy soil. The backfill material shall be spread uniformly in layers, levelled, watered and then compacted to 95% of its optimum density in layers not exceeding 200 mm for buildings works and 250 mm for others. Compaction may be done manually or with mechanical</p>
-------------------------------	------------------------	--

		<p>means. Manual compaction in each layer will be done using 2 to 5 kg rammers made of cast-iron or wood. Mechanical compaction shall be executed with either plate compactors, earth rammers, depending on site conditions.</p> <p>Compaction tests shall be conducted with sand cones using relevant BS or ASTM standards.</p> <p>Transportation And Handling Of Excess Disposable Material</p> <p>This work will be required in connection with transportation of materials from demolition works (unless otherwise specified) and excess suitable or unsuitable material from excavation. Transport will include all distance beyond the initial lead (30m unless otherwise specified) for safe disposal as specified by the Engineer. Activities involved will be supply of necessary means of transport, loading, and transportation safely without damage/loss, unloading and levelling properly at disposal sites. The disposed materials shall be laid in layers mechanically or manually compacted to the satisfaction of the Engineer.</p> <p>The excess material shall be disposed manually with or without equipment like wheelbarrows or by trucks depending on the location of disposal sites.</p> <p>Measurement</p> <p>Measurement will be based first in m³ of loose volume of accepted works with 35% deduction for voids for all leads indicated in the BOQ. The measurement will be made at the disposal site.</p> <p>Payment</p> <p>Payment for work under this Clause will be made on the basis of contract unit price indicated in the BOQ. The payment will be full and final compensation for all material, labor, and equipment to complete the works as specified.</p>
C. Masonry Works		
	General	<p>Mortar</p> <p>Mortar shall comply with IS 2250-1981; Code of Practice for preparation and use of masonry mortar. The mortar used in work shall have the strength not less than 5 N/mm² or 7.5 N/mm² at 28 days as specified.</p> <p>However, if provided in the Contract, cement and sand may also be mixed in specified proportions. Cement shall be proportioned only by weight, by taking its unit weight as 1.44 ton per cubic meter and sand shall be proportioned by volume after making due allowance for bulking.</p> <p>Mixing</p> <p>The mixing shall be done in a mechanical mixer unless hand-mixing is permitted by the Engineer. If hand-mixing is allowed, the operation shall be carried out on a clear watertight platform. In the required proportion cement and sand shall be first mixed dry to obtain an uniform colour. Then required quantity of water shall be added and the mortar shall be mixed to produce workable consistency. The mortar shall be mixed for at least three minutes after addition of water in the case of mechanical mixing. In the case of hand mixing, the mortar shall be hoed back and forth for about 10</p>

		<p>minutes after addition of water in order to obtain uniform consistency.</p> <p>Only that quantity of mortar shall be mixed at a time which can be used completely before it becomes unworkable. Any mortar that has become unworkable due to loss of water before elapsing the initial setting time of cement shall be rewet to make it workable and shall be used in the works. On no account mortar shall be used after elapsing the initial setting time of cement.</p> <p>Soaking Of Bricks</p> <p>Bricks shall be soaked in water for a minimum period of one hour before use. When bricks are soaked they shall be removed from the tank sufficiently in advance so that at the time of laying they are skin dry. Such soaked bricks shall be stacked on a clean place where they are not spoilt by dirt, earth, etc.</p> <p>Laying Brickwork</p> <p>The brick shall be built in English bond with upwards facing frog in case of 230mm thick brickwork (for chimney made and fair faced machine made bricks both).</p> <p>The brick shall be built in running stretcher bond with upwards facing frog in case of half brick wall (for chimney made, traditional dachi appa brickwork and machine made both).</p> <p>Each brick shall be set with bed and vertical joints filled thoroughly with mortar. Selected bricks shall be used for the exposed brickwork as specified under 7.1.2. The walls shall be taken up truly plumb. All courses shall be laid truly horizontal and vertical joints shall be truly vertical. Vertical joints in alternate course shall come directly over the other. The thickness of brick courses shall be kept uniform and for this purpose wooden straight edge with graduation giving thickness of each brick course including joint shall be used. Necessary tools comprising of wooden straight edge, masons sprit level, square, foot rule, plumb, line and pins etc. shall be frequently and fully used by the masons to ensure that the walls are taken up true to plumb, line and levels.</p> <p>Both the faces of walls of thickness greater than 23cm shall be kept in proper plane. All the connected brickwork shall be carried up nearly at one level and no partition of work shall be raised more than one meter above the rest of the work. Any dislodged brick shall be removed and reset in fresh mortar.</p> <p>Before commencing any brickwork, the Contractor shall confer with other trades to ensure that all pipes, conduits, drains, sleeves, bolts, hangers, or any other materials necessary to be installed in the brickwork at the time it is built, have been fixed or provided for.</p> <p>Joints</p> <p>Bricks shall be laid that all joints are full of mortar. The thickness of joints shall be not more than 10mm. The face joints shall be raked to a minimum depth of 7mm by a raking tool during the progress of the work when the mortar is still green, so as to provide proper key for the plaster or pointing to be done. Where plastering pointing is not to be done, the joints shall be struck flush and finished at the time of laying. The face of brickwork shall be kept cleaned and mortar dropping removed.</p>
--	--	--

		<p>When fresh masonry is to be placed against existing surface of structures, the surface shall be cleaned of all loose materials, roughened and wetted as directed by the Engineer so as to effect a good bond with the new work.</p> <p>Openings Openings in brickwork for air conditioning ducts, exhaust fans, grills pipes etc. shall be provided at the time of laying brickwork without any extra cost.</p> <p>After installation of piping, conduits, grills, etc. all openings left around pipes, conduits, grills etc. shall be checked and caulked with cement mortar to render the whole work vermin proof and tidily finished.</p> <p>The rates quoted are deemed to be inclusive of closing such pre determined openings including erection and dismantling of scaffolding if required, the placing of inserts, collars, grills etc. to be paid separately under respective items.</p> <p>Curing Green work shall be protected from rain by suitable covering. Masonry work in cement mortar shall be kept constantly moist on all faces for a minimum period of seven days. The top of the masonry work shall be left flooded with water so as not to disturb or washout the green mortar.</p> <p>During hot weather, all finished or partly completed work shall be covered or wetted in such a manner as to prevent rapid drying of the brick work.</p> <p>Scaffolding The scaffolding shall be sound and strong to withstand all loads likely to come upon it. The holes which provide resting space for horizontal members shall not be left in masonry under one meter in width or immediately near the skew backs of arches. The holes left in the masonry work for supporting the scaffolding shall be filled and made good.</p> <p>Condition Of Equipment All equipment used for mixing or transporting mortar and bricks shall be clean and free from set mortar, dirt or other injurious foreign substances.</p> <p>Walling Building: Bricks shall be wetted before being laid and the top of walling where left off shall be wetted before re-commencing building. Walls to be kept wet three days after building.</p> <p>Bricks shall be well buttered with mortar before being laid and the brickwork carried up evenly course so that no part is allowed to be carried up more than 90cm higher at any time than any other part.</p> <p>Cavity Walling Building The two layer of half brick wall with half brick cavity is cavity walling of the building. Bricks shall be wetted before being laid and the top of walling where left off shall be wetted before re-commencing building. Each left brick wall shall be connected by 10G GI links made as per design at every five course vertically and at the 60cm</p>
--	--	--

	<p>spacing horizontally or as per drawing. The two courses below sill will be solid wall. One or both half brick wall will be laid in fair face in stretcher bond. The walls are to be kept wet three days after building.</p> <p>Bricks shall be well buttered with mortar before being laid and the brickwork carried up evenly course-by-course so that no part is allowed to be carried up more than 90cm higher at any time than any other part.</p> <p>Setting out Walling</p> <p>The contractor shall provide proper setting- out rods and set out all work on it for corners, openings, heights, etc. And shall build the walls and piers etc. To the width, depth and height indicated on the drawings and as directed and approved by the Engineer in-charge.</p> <p>Bonding Walls</p> <p>Load bearing brickwork generally shall be of Quota bond (nominal thickness 350mm) and reinforced as shown on the detailed drawings. One brick walls (nominal thickness 230mm) shall be in English bond and half brick walls (nominal thickness 115mm) in Stretcher bond. No broken bricks or bats shall be used unless required to from bond.</p> <p>All propounds, quoins, reveals and other angles of walls shall be built strictly true and square.</p> <p>Cement & sand shall be as before specified.</p> <p>Lime shall be freshly burnt lime slaked at least one month before being used by drenching with water, well broken up and mixed and the slurry passed through a 3mm mesh screen to remove all lumps and impurities.</p> <p>Filling for Brick work</p> <p>Where brickwork cavities are specified to contain reinforcing bars they shall be filled with concrete mix as previously described. The filling shall be placed and consolidated in section not exceeding 90cm in height. Cavities that are to be filled shall be kept free of all mortar dropping.</p> <p>Brick Lintels</p> <p>Lintels over doors and under openings except where in concrete, shall be formed in brick work by reinforcing the three concrete immediately above the opening with steel wire reinforcement projecting 45cm at either end of the opening and the rates are to include for any necessary centring.</p> <p>Putlog Holes</p> <p>All putlog holes shall be not less than one course deep and carefully filled with bricks cut to fit size of opening with beds and joints filled with mortar well tamped in after scaffolding is removed.</p> <p>Keeping Clean</p> <p>The contractor shall allow in his rates for keeping the fair-faced brickwork free from mortar at all times and for cleaning the work at completion.</p> <p>Construction Joints between Walls</p> <p>Where Construction joints indicated on the drawings should be filled by 25*100m flexible jute carpet coated with bitumen and covered by 16G galvanized steel sheet in exposed faces. All the construction</p>
--	--

		<p>Reinforced Brickwork All brickwork shall be reinforced with Torsteel or equivalent reinforcement both horizontally and vertically, as per drawing and instruction of engineer. The reinforcement cleaned of rust and loose flakes with a wire brush, shall be embedded thoroughly in cement mortar at every fourth course. It shall be cast in or securely fixed to adjoining columns or walls, in a manner approved by the Engineer.</p> <p>Jointing In jointing, the face joints of the mortar shall be worked out while still green to give a finished surface flush with the face of the brick-work. The faces of brick-work shall be cleaned to remove any splashes of mortar during the course of raising the brick-work. The measurement of brickwork both 230mm (above 230mm, if any) and 115mm thick shall be the product of the length, height and thickness i.e. in cubic meter for chimney made and fair faced machine made brickwork. Deduction for doors, windows and other openings including lintels shall be made to arrive at the net quantity of work. Nothing shall be paid extra for forming such openings. However, no deductions shall be made for areas less than 0.1 sqm. overall, bearing of lintels, beams, girders and hold fasts blocks but nothing extra like form work shall be paid for embedding these. Similarly, no deductions shall be made for chimney flue left in the walls, but nothing extra shall be allowed for rendering for flue openings as specified. Unless otherwise specified nothing extra shall be admissible for cutting shape other than straight or any cutting necessary for shaping the walls to the structural design. Rate shall be inclusive of all necessary scaffolding, watering, cutting of bricks, curing, vertical & horizontal reinforcement within brickwork, materials and labor.</p>
C1	Chimney made Bricks	<p>The Brick shall be first class chimney made bricks of quality approved by the Engineer and free from grit and other impurities such as lime, iron and other deleterious salts, conforming NS 1 2035 / IS code (latest revision). These shall be well burnt, sound, and hard with sharp edges and shall emit ringing sound when struck with a mallet. These shall be of uniform size. The size of the bricks shall be 22.9cm x 11.2cm x 5.5cm unless otherwise specified, with a tolerance of ± 3mm in each direction.</p>
		<p>Cleaning Remove excess mortar from glass surfaces with a damp cloth before set occurs. The glass block wall shall be left clean and unblemished condition. The residue of cement on the glass surface let from mortar/ tiling grout shall be removed by use of proprietary cement stain remover. Hydrofluoric acid or derivatives must not be used. No scratch marks of blades shall be seen in the glass surface.</p> <p>Protection Protect installed products shall be protected until completion of project. Damaged products shall be Touched-up, repaired or replaced before Substantial Completion</p> <p>Measurement/ payment Measurement shall be in square meter for specified thickness of masonry or nos of glass blocks as specified in the BOQ. Rate shall include materials, mixing, laying, finishing, and labor etc., all complete.</p>

D1-D8	General	<p>Mixing Concrete</p> <p>Before any batching, mixing, transporting, placing, compacting and finishing and curing the concrete ordered or delivered to site, the Contractor shall submit to the Engineer full details including Drawing of all the plant which he proposes to use and the arrangements he proposes to make.</p> <p>Concrete for the works shall be batched and mixed in one or more plants or concrete mixer unless the Engineer agrees to some other arrangement. If concrete mixers are used, there shall be sufficient number of mixtures including stand by mixers.</p> <p>Batching and mixing plants shall be complying with the requirements of IS 1791 and capable of producing a uniform distribution of the ingredients throughout the mass. Truck mixers shall comply with the requirements of IS 4925 and shall only be used with the prior approval of the Engineer. If the plant proposed by the Contractor does not fall within the scope of IS 1791 it shall have been tested in accordance with IS 4634 and shall have a mixing performance within the limits of IS 1791.</p> <p>All mixing operations shall be under the control of an experienced supervisor.</p> <p>The aggregate storage bins shall be provided with drainage facilities arranged so that the drainage water is not discharged to the weigh hoppers. Each bin shall be drawn down at least once per week and any accumulations of mud or silt shall be removed.</p> <p>If bulk cement is used, the scale and weight hopper for cement shall be distinct from the scale and weight hopper for aggregates.</p> <p>Cement and aggregates shall be batched by weight. Water may be measured by weight or volume.</p> <p>The weighing and water dispensing mechanisms shall be maintained in good order. Their accuracy shall be maintained within the tolerances described in IS 1791 and not more than plus or minus one percent, and checked against accurate weights and volumes when required by the Engineer.</p> <p>The weights of cement and of each size of aggregate and the weight or volume of water as indicated by the mechanism employed shall be within a tolerance of plus or minus three per cent of the respective weight per batch agreed by the Engineer.</p> <p>The Contractor shall provide standard test weights at least equivalent to the maximum working load used on the most heavily loaded scale and other auxiliary equipment required for checking the satisfactory operation of each scale or measuring device. Tests shall be made by the Contractor in the presence of the Engineer during the site trials described in Sub-clause 604 (4) and then at intervals to be determined by the Engineer but not less than once per three months.</p> <p>The Contractor shall furnish the Engineer with copies of the complete results of all check tests and shall make any adjustments, repairs or replacements necessary to ensure satisfactory performance.</p> <p>The nominal drum or pan capacity of the mixer shall not be exceeded.</p> <p>The turning speed and the mixing time shall be as recommended by the manufacturer, but in addition, when water is the last ingredient to</p>
-------	---------	---

		<p>be added, mixing shall continue for at least one minute after all the water has been added to the drum or the pan.</p> <p>The blades of pan mixers shall be maintained within the tolerances specified by the manufacturer of the mixer and the blades shall be replaced when it is no longer possible to maintain the tolerances by adjustment.</p> <p>Mixers shall be fitted with an automatic recorder registering the number of batches discharged.</p> <p>The water to be added to the mix shall be reduced by the amount of free water contained in the coarse and fine aggregates. This amount shall be determined by the Contractor by a method agreed by the Engineer immediately before mixing begins each day and thereafter at least once per hour and for each delivery of aggregates during concreting. When the correct quantity of water, determined as set out in the Specification, has been added to the mix, no further water shall be added, either during mixing or subsequently.</p> <p>Mixers which have been out of use for more than 30 minutes shall be thoroughly cleaned before any fresh concrete is mixed. Mixers shall be cleaned out before changing to another type of cement.</p> <p>Transportation Of Concrete</p> <p>The concrete shall be discharged from the mixer and transported to the works by means which shall prevent adulteration, segregation or loss of ingredients, and shall ensure that the concrete is of the required workability at the point and time of placing. The loss of slump between discharge from the mixer and placing shall be within the tolerances.</p> <p>The capacity of the means of transport shall not be less than the full volume of a batch.</p> <p>The time elapsing between mixing transporting placing and compaction altogether of a batch of concrete shall not be longer than the initial setting time of the concrete. If the placing of any batch of concrete is delayed beyond this period, the concrete shall not be placed in the works.</p> <p>Placing Of Concrete</p> <p>Consent for Placing</p> <p>Concrete shall not be placed until the Engineer's consent has been given in writing. The Contractor shall give the Engineer at least two full working day notice of his intention to place concrete.</p> <p>If concrete placing is not commenced within 24 hours of the Engineer's consent the Contractor shall again request consent as specified above.</p> <p>Preparation of Surface to Receive Concrete</p> <p>Excavated surfaces on which concrete is to be deposited shall be prepared as set out in relevant Section Existing concrete surfaces shall be prepared before deposition of further concrete they shall be clean, hard and sound and shall be wet but without any free-standing water.</p> <p>Any flow of water into an excavation shall be diverted through proper side drains to a sump or be removed by other suitable method which will prevent washing away the freshly deposited concrete or any of its</p>
--	--	--

		<p>constituents. Any under drain constructed for this purpose shall be completely grouted up when they are no longer required by a method agreed by the Engineer.</p> <p>Unless otherwise instructed by the Engineer surfaces against which concrete is to be placed shall receive prior coating of cement slurry or mortar mixed in the proportions similar to those of the fines portion in the concrete to be placed. The mortar shall be kept ahead of the concrete. The mortar shall be placed into all parts of the excavated surface and shall not be less than 5 mm thick.</p> <p>If any fissures have been cleaned out they shall be filled with mortar or with concrete as instructed by the Engineer.</p> <p>The amount of mortar placed at one time shall be limited so that it does not dry out or set before being covered with concrete.</p> <p>Placing Procedures</p> <p>The concrete shall be deposited as nearly as possible in its final position. It shall be placed so as to avoid segregation of the concrete and displacement of the reinforcement, other embedded items or formwork. It shall be brought up in layers approximately parallel to the construction joint planes and not exceeding 300 mm in compacted thickness unless otherwise permitted or directed by the Engineer, but the layers shall not be thinner than four times the maximum nominal size of aggregate.</p> <p>When placing on a nearly horizontal surface, placing shall start at the lower end of the surface to avoid de-compaction of concrete.</p> <p>Layers shall not be placed so that they form feather edges nor shall they be placed on a previous layer which has taken its initial set. In order to comply with this requirement, another layer may be started before initial set of the preceding layer.</p> <p>All the concrete in a single bay or pour shall be placed as a continuous operation. It shall be carefully worked round all obstructions, irregularities in the foundations and the like so that all parts are completely full of compacted concrete with no segregation or honey combing. It shall also be carefully worked round and between water stops, reinforcement, embedded steelwork and similar items which protrude above the surface of the completed pour. All work shall be completed on each batch of concrete before its initial set commences and thereafter the concrete shall not be disturbed before it has set hard. No concrete that has partially hardened during transit shall be used in the works and the transport of concrete from the mixer to the point of placing shall be such that this requirement can be complied with.</p> <p>Concrete shall not be placed during rain which is sufficiently heavy or prolonged to wash mortar from coarse aggregate on the exposed faces of fresh concrete. Means shall be provided to remove any water accumulating on the surface of the placed concrete. Concrete shall not be deposited into such accumulations of water.</p> <p>In dry weather, covers shall be provided for all fresh concrete surfaces which are not being worked on. Water shall not be added to concrete for any reason.</p>
--	--	--

		<p>When concrete is discharged from the place above its final deposition, segregation shall be prevented by the use of chutes, down pipes, trunking, baffles or other appropriate devices.</p> <p>Forms for walls shall be provided with openings or other devices that will permit the concrete to be placed in a manner that will prevent segregation and accumulations of hardened concrete on the formwork or reinforcement above the level of the placed concrete.</p> <p>When it is necessary to place concrete under water the Contractor shall submit to the Engineer his proposals for the method and equipment to be employed. The concrete shall be deposited either by bottom-discharging watertight containers or through funnel-shaped tremies which are kept continuously full with concrete in order to reduce to a minimum the contact of the concrete with the water. Special care shall be taken to avoid segregation.</p> <p>If the level of concrete in a tremie pipe is allowed to fall to such extent that the water enters the pipe, the latter shall be removed from the pour and filled with concrete before being again lowered into the placing position. During and after concreting under water, pumping or de-watering in the immediate vicinity shall be suspended if there is any danger that such work will disturb the freshly placed concrete.</p> <p>Interruptions to Placing</p> <p>If the concrete placing is interrupted for any reason and the duration of the interruption cannot be forecast or is likely to be prolonged, the Contractor shall immediately take the necessary action to form a construction joint so as to eliminate as far as possible feather edges and sloping top surfaces and shall thoroughly compact the concrete. All work on the concrete shall be completed before elapse of initial setting time and it shall not thereafter be disturbed until it is hard enough to resist damage. Plant and materials to comply with this requirement shall be readily available at all time during concrete placing.</p> <p>Before concreting is resumed after such an interruption the Contractor shall cut out and remedy all damaged or un-compacted concrete, feather edges or any undesirable features and shall leave a clean sound surface against which the fresh concrete may be placed.</p> <p>If it becomes possible to resume concrete placing without contravening the Specification and the Engineer consents to resumption, the new concrete shall be thoroughly worked in and compacted against the existing concrete so as to eliminate any cold joints.</p> <p>In case of long interruption concrete shall be resumed as directed by Engineer.</p> <p>Dimensions of Pours</p> <p>Unless otherwise agreed by the Engineer, pours shall not be more than two meters high and shall as far as possible have a uniform thickness over the plan area of the pour. Concrete shall be placed to the full planned height of all pours except in the circumstances described. The Contractor shall plan the dimensions and sequence of pours in such a way that cracking of the concrete does not take place due to thermal or shrinkage stresses</p>
--	--	--

		<p>Placing Sequence</p> <p>The Contractor shall arrange that the intervals between successive lifts of concrete in one Section of the works are of equal duration. This duration shall not be less than three days or not more than seven days under temperate weather conditions unless otherwise agreed by the Engineer.</p> <p>Where required by the Engineer to limit the opening of construction joints due to shrinkage, concrete shall not be placed against adjacent concrete which is less than 21 days old.</p> <p>Contraction gaps in concrete shall be of the widths and in the locations as shown on the Drawing and they shall not be filled until the full time interval shown on the Drawing has elapsed.</p> <p>Compaction Of Concrete</p> <p>Concrete shall be fully compacted throughout the full extent of the placed layer. It shall be thoroughly worked against the formwork and around any reinforcement and other embedded item, without displacing them. Care shall be taken at arises or other confined spaces. Successive layers of the same pour shall be thoroughly worked together.</p> <p>Concrete shall be compacted with the assistance of mechanical immersion vibrators, unless the Engineer agrees another method.</p> <p>Immersion and surface vibrators shall operate at a frequency of between 70 and 200 hertz. The Contractor shall ensure that vibrators are operated at pressures and voltages not less than those recommended by the manufacturer in order that the compactive effort is not reduced.</p> <p>A sufficient number of vibrators shall be operated to enable the entire quantity of concrete being placed to be vibrated for the necessary period and, in addition, stand-by vibrators shall be available for instant use at each place where concrete is being placed.</p> <p>Vibration shall be continued at each point until the concrete ceases to contract, air bubbles have ceased to appear, and a thin layer of mortar has appeared on the surface. Vibrators shall not be used to move concrete laterally and shall be withdrawn slowly to prevent the formation of voids.</p> <p>The vibrators shall be inserted vertically into the concrete to penetrate the layer underneath at regular spacing which shall not exceed the distance from the vibrator over which vibration is visibly effective and some extent of vibration is overlapped.</p> <p>Vibration shall not be applied by way of reinforcement nor shall the vibrators be allowed to touch reinforcement, sheathing ducts or other embedded items.</p> <p>Coarse Aggregate As per item (4) page 31</p> <p>Fine Aggregate As per item (3) page 31</p> <p>Cement As per item (2) page 30</p> <p>Water As per item (7) page 33</p>
--	--	---

		<p>Tests</p> <p>Regular Slump test should be carried out to control the addition of water and to maintain required consistency.</p> <p>Curing Of Concrete</p> <p>General</p> <p>Concrete shall be protected during the first stage of hardening from loss of moisture and from the development of temperatures differentials within the concrete sufficient to cause cracking. The methods used for curing shall not cause damage of any kind to the concrete.</p> <p>Curing shall be continued for as long as may be necessary to achieve the above objectives but not less than seven days or until the concrete is covered by successive construction whichever is the shorter period.</p> <p>The above objectives shall be dealt with but nothing shall prevent both objectives being achieved by a single method where circumstances permit.</p> <p>The curing process shall commence as soon as the concrete is hard enough to resist damage from the process. In the case of large areas or continuous pours, it shall commence on the completed Section of the pour before the rest of the pour is finished.</p> <p>Loss of Moisture</p> <p>Exposed concrete surfaces shall be closely covered with impermeable sheeting, properly secured to prevent its removal by wind and the development of air spaces beneath it. Joints in the sheeting shall be lapped by at least 300 mm.</p> <p>If it is not possible to use impermeable sheeting, the Contractor shall keep the exposed surfaces continuously wet by means of water spray or by covering with a water absorbent material which shall be kept wet, unless this method conflicts with provisions of relevant Sub-clause.</p> <p>Water used for curing shall be of the same quality as that used for mixing.</p> <p>Formed surfaces may be cured by retaining the formwork in place for the required curing period.</p> <p>If instructed by the Engineer, the Contractor shall, in addition to the curing provisions set out above provide a suitable form of shading to prevent the direct rays of the sun reaching the concrete surfaces for at least the first four days of the curing period.</p> <p>Limitation of Temperature Differentials</p> <p>The Contractor shall limit the development of temperature differentials in concrete after placing by any means appropriate to the circumstances including the following:</p> <ul style="list-style-type: none">Limiting concrete temperatures at placing);Use of low heat cement for mass concreting, subject to the agreement of the Engineer;Leaving formwork in place during the curing period. Steel forms shall be suitably insulated on the outside;Preventing rapid dissipation of heat from surfaces by shielding from wind.
--	--	---

		<p>Protection Of Fresh Concrete Freshly placed concrete shall be protected from rainfall and from water running over the surface until it is sufficiently hard to resist damage from these causes. Concrete placed in the works shall not be subjected to any loading including traffic until it has attained at least its characteristic strength.</p> <p>Concreting In Hot Weather General The Contractor shall prevent damage to concrete arising from exposure to extreme temperatures, and shall maintain in good working order all plant and equipment required for this purpose. In the event that conditions become such that even with the use of equipment the requirements cannot be met, concrete placing shall immediately cease until such time as the requirements can again be met.</p> <p>Concrete Placing in Hot Weather During hot weather the Contractor shall take all measures necessary to ensure that the temperature of concrete at the time of placing in the works does not exceed 30°C and that the concrete does not lose any moisture during transporting and placing. Such measures may include but are not necessarily limited to the following:- Shielding aggregates from direct sunshine. Use of a mist water spray on aggregates. Sun shields on mixing plants and transporting equipment. Surfaces in which concrete is to be placed shall be shielded from direct sunshine and surfaces shall be thoroughly wetted to reduce absorption of water from the concrete placed on or against them. After concrete has been placed, the selected curing process shall be commenced as soon as possible. If any interval occurs between completion of placing and start of curing, the concrete shall be closely covered during the interval with polythene sheet to prevent loss of moisture.</p> <p>Construction Joints Whenever concrete is to be bonded to other concrete which has hardened, the surface of contact between the Sections shall be deemed a construction joint. Where construction joints are shown in the Drawing, the Contractor shall form such joints in such positions. The location of joints which the Contractor requires to make for the purpose of construction shall be subject to the approval of the Engineer. Construction joints shall be in vertical or horizontal planes except in sloping slabs where they shall be normal to the exposed surface or elsewhere where the Drawing requires a different arrangement. Construction joints shall be arranged as to reduce to a minimum the effects of shrinkage in the concrete after placing, and shall be placed in the most advantageous positions with regard to stresses in the structures and the desirability of staggering joints.</p>
--	--	--

		<p>Feather edges of concrete at joints shall be avoided. Any feather edges which may have formed where reinforcing bars project through a joint shall be cut back until sound concrete has been reached.</p> <p>The intersections of horizontal and near horizontal joints and exposed faces of concrete shall appear as straight lines produced by use of a guide strip fixed to the formwork at the top of the concrete lift, or by other means acceptable to the Engineer.</p> <p>Construction joints formed as free surfaces shall not exceed a slope of 20 per cent from the horizontal.</p> <p>The surface of the fresh concrete in horizontal or near horizontal joints shall be thoroughly cleaned and roughened by means of high pressure water, and air jets or wire brush, when the concrete is hard enough to withstand the treatment without the leaching of cement.</p> <p>The surface of vertical or near vertical joints shall be similarly treated if circumstances permit the removal of formwork at a suitable time.</p> <p>Where concrete has become too hard for the above treatment to be successful, the surface whether formed or free shall be thoroughly scabbled by mechanical means, manually or wet sand blasted and then washed with clean water. The indentations produced by scabbling shall not be less than 10 mm deep and shall be away from the finished face by 40mm.</p> <p>If instructed by the Engineer the surface of the concrete shall be thoroughly brushed with a thin layer of mortar composed of one part of cement to two parts of sand by weight immediately prior to the deposition of fresh concrete. The mortar shall be kept just ahead of the fresh concrete being placed and the fresh layer of concrete shall be thoroughly and systematically vibrated to full depth to ensure complete bond with the adjacent layer. No mortar or concrete shall be placed until the joint has been inspected and approved by the Engineer.</p> <p>Records Of Concrete Placing</p> <p>Records of the details of every pour of concrete placed in the works shall be kept by the Contractor in a form agreed by the Engineer. These records shall include class of concrete, location of pour, date and duration of pour, ambient temperature and concrete temperature at time of placing and all relevant meteorological information such as rain, wind etc., moisture contents of the aggregates, details of mixes, batch numbers, cement batch number, results of all tests undertaken, part of the structure and place where test cube samples are taken from.</p> <p>The Contractor shall supply to the Engineer four copies of these records each week covering work carried out the preceding week. In addition he shall supply to the Engineer monthly histograms of all 28 day cubes strength results together with cumulative and monthly standard deviations, Coefficient of Variation, and any other information which the Engineer may require concerning the concrete placed in the works.</p>
--	--	--

		<p>No Fines Concrete No Fines concrete (NF concrete) is intended for use where a porous concrete is required and shall only be used where shown on the Drawing or instructed by the Engineer. The mix shall consist of Ordinary Portland cement and aggregate complying with this Specification. The aggregate size shall be 40 mm to 10 mm only. The weight of cement mixed with 0.3 cubic meters of aggregate shall not be less than 50 kg. The quantity of water shall not exceed that required to produce a smooth cement paste which will coat evenly the whole of the aggregate.</p> <p>Hand Mixed Concrete Concrete for structural purposes shall not be mixed by hand. Where non structural concrete is required, hand mixing may be carried out subject to approval of the Engineer. For making hand mixed concrete, cement, sand and aggregate shall be batched separately by volume or by weight as applicable. Mixing shall be done in masonry platform or sheet iron tray. Then cement and sand shall be mixed dry to uniform colour. The aggregate shall be stacked in a proper shape upon which cement sand mix shall be spread and whole mix shall be turned up and down to have uniform mix of all ingredients. Then water shall be added and shall be mixed to uniform consistency. For hand mixed concrete the specified quantities of cement shall be increased by 10% and not more than 0.25 cubic meters shall be mixed at one time. During windy weather precautions shall be taken to prevent cement from being blown away in the process of gauging and mixing.</p> <p>Early Loading No load shall be applied to any part of a structure until the specified curing period has expired, and thereafter loading shall be allowed after approval by the Engineer. The Engineer's decision shall be based on the type of load to be applied, the age of concrete, the magnitude of stress induced and the propping of the structure. No structure shall be opened to traffic until test cubes have attained the specified minimum 28 days strength</p> <p>Measurement Concrete Concrete laid in place as specified in the Drawing or directed by the Engineer shall be measured in cubic meter separately for each class. No deduction shall be made in the measurement for: bolt holes, pockets, box outs and cast in components provided that the volume of each is less than 0.15 cubic meters; mortar beds, fillets, drips, rebates, recesses, grooves, chamfers and the like of 100 mm total width or less; reinforcement</p> <p>Blinding Concrete/Non Structural Concrete Blinding concrete laid in place shall be measured in cubic meter. No deduction shall be made for openings provided that the area of each is less than 0.5 square meters. Blinding concrete over hard material shall be measured as the volume used provided that the maximum</p>
--	--	--

		<p>thickness of 150 mm allowed for over break is not exceeded.</p> <p>Admixtures, Workability and Hardening Agents Measurement of these items shall be carried out as specified in the contract.</p> <p>Concrete Every class of concrete shall be paid as per respective contract unit rate. The respective rate shall also include the cost of: Admixtures and workability agents including submission of details unless specified. Class of UF1,2 or 3 surface finish. Laying to sloping surfaces not exceeding 15° from the horizontal and to falls. Formwork to lean concrete. Placing and compacting against excavated surfaces where required including any additional concrete to fill over break and working space. Complying with the requirements of Clauses 2001 to 2013,1806 and 1807.</p> <p>Admixtures, Workability and Hardening Agents Payment shall be made at contract unit rate which shall be the full and the final compensation to the Contractor for all specified in the contract.</p>
D1	Non-structural Concrete	<p>Non-structural concrete (NS concrete) shall be used only for non structural purposes where shown on the Drawing. NS concrete shall be compound of ordinary Portland cement and aggregates complying with this Specification. The weight of cement mixed with 0.3 cubic meters of combined aggregate shall not be less than 50 kg. The mix shall be proportioned by weight or by volume. The maximum aggregate size shall be 40 mm nominal. The concrete shall be mixed by machine or by hand to a uniform colour and consistency before placing. The quantity of water used shall not exceed that required to produce a concrete with sufficient workability to be placed and compacted where required. The concrete shall be compacted by hand towels or rammers or by mechanical vibration.</p>
D9	Reinforcement	<p>Reinforcement as plain bars and deformed bars and steel fabric shall comply with the following Indian Standards. IS 1786 for high strength deformed steel bars and wires. IS 1566 for steel mesh fabric. IS 432 mild steel and medium tensile steel bars. All reinforcement shall be from an approved manufacturer and, if required by the Engineer, the Contractor shall submit the ISI certification mark or other test certificate from the manufacturer acceptable to the Engineer. The Contractor shall furnish all information as manufacturer's certificate, invoice, and other relevant details to ensure the quality of steel. The reinforcements shall have no crack, scale or rust or foreign particles that will destroy or reduce the bond. The bars shall be accurately bent and formed to the dimension indicated in the</p>

		<p>Drawings. The Contractor shall prepare bending schedules for each structure and calculate the weight of the reinforcement. The schedule of bars and the calculations shall be submitted to the Engineer for approval.</p> <p>Binding wire used to bind reinforcements shall be annealed galvanized binding wire of 20 gauges.</p> <p>The sampling and frequency of testing shall be as set out in the NS 84-2042 and NS 191-2045. All reinforcement not complying with the Specification shall be removed from site.</p> <p>Storage of Reinforcement</p> <p>All reinforcement shall be delivered to site either in straight lengths or cut and bent. No reinforcement shall be accepted in long lengths which have been transported bent over double.</p> <p>Any reinforcement which is likely to remain in storage for a long period shall be protected from the weather so as to avoid corrosion and pitting. All reinforcement which has become corroded or pitted to an extent which, in the opinion of the Engineer, will affect its properties shall either be removed from site or may be tested for compliance with the appropriate Indian Standard at the Contractor expense.</p> <p>Reinforcement shall be stored at least 150mm above the ground on a clean area free of mud and dirt and sorted out according to category, quality and diameter.</p> <p>Bending Reinforcement</p> <p>Unless otherwise shown on the Drawing, bending and cutting shall comply with IS 2502.</p> <p>The Contractor shall satisfy himself as to the accuracy of any bar bending schedules supplied and shall be responsible for cutting, bending, and fixing the reinforcement in accordance with the Drawing. Bars shall be bent mechanically using appropriate bar benders. Bars shall be bent cold by the application of slow steady pressure. At temperatures below 5°C the rate of bending shall be reduced if necessary to prevent fracture in the steel.</p> <p>Bending reinforcement inside the forms shall not be permitted except for mild steel bars of diameter less or equal to 12 mm, when it is absolutely necessary.</p> <p>After bending, bars shall be securely tied together in bundles or groups and legibly labelled as set out in IS2502.</p> <p>Fixing Reinforcement</p> <p>Reinforcement shall be thoroughly cleaned. All dirt, scale, loose rust, oil and other contaminants shall be removed before placing it in position. If the reinforcement is contaminated with concrete from previous operations, it shall be cleaned before concreting in that Section.</p> <p>Reinforcement shall be securely placed and fixed in position as shown in the drawing or directed by the Engineer.</p> <p>Unless otherwise agreed by the Engineer, all intersecting bars shall be either tied together with not less than 1.6 mm diameter soft annealed iron wire and the end of the wire turned into the body of the concrete, or shall be secured with a wire clip of a type agreed by the Engineer.</p>
--	--	---

		<p>Spacer blocks shall be used for ensuring that the correct cover is maintained on the reinforcement. Blocks shall be as small as practicable and of a shape agreed by the Engineer. They shall be made of mortar mixed in the proportions of one part of cement to two parts of sand by weight. Wires cast into the block for tying in to the reinforcement shall have not less than 1.6 mm diameter and shall be soft annealed iron.</p> <p>Alternatively another type of spacer block may be used subject to the Engineer's approval. All reinforcement shall be checked of shape, size, diameter and number where necessary. Reinforcement shall be rigidly fixed so that it remains intact during placing of concrete. Any fixers Made to the formwork shall not remain within the space to be occupied by the concrete being placed.</p> <p>No splices shall be made in the reinforcement except where shown on the Drawing or agreed by the Engineer. Splice lengths shall be as shown on the Drawing or directed by the Engineer.</p> <p>Reinforcement shall not be welded except where required by the contract or agreed by the Engineer. If welding is employed, all welded splices shall be full penetration butt welds complying with the procedures set out in IS 2751 or IS 9417 as applicable. Mechanical splices shall not be used unless the Engineer agrees otherwise. Acceptance for welded or mechanical splices of approved design shall be based on qualification tests to be carried out by the Contractor: prior to start of the work. Construction control testing as instructed by the Engineer shall be also carried out.</p> <p>The Contractor shall ensure that reinforcement left exposed in the works shall not suffer distortion, displacement or other damage. When it is necessary to bend protruding reinforcement aside temporarily, the radius of the bend shall not be less than four times the bar diameter for mild steel bars or six times the bar diameter for high yield bars. Such bends shall be carefully straightened without leaving residual kinks or damaging the concrete round them before concrete placing. In no circumstances heating and bending of high yield bars shall be permitted.</p> <p>Bars complying with IS 1786 or other high tensile bars shall not be bent after placing in the works.</p> <p>The reinforcement shall be paid at contract unit rate. The rate shall also include compensation for the cost of providing, cutting to length, cleaning, spacer blocks, waste incurred by cutting, welding, fixing the reinforcement in position including the provision of wire or other material for supporting and tying the reinforcement in place, bending reinforcement aside temporarily, and straightening, placing and compacting concrete around reinforcementand. Exact length of laps, bending, hooking, and provision and fixing of chairs of atleast 12 mm dia shall be separately measured for payment.</p>
		<p>Formworks As per E1-E13</p> <p>Fabric Reinforcement The fabric reinforcement shall be paid at contract unit rate which shall be also inclusive of compensation for wastage and laps.</p>

E. Formworks and Waling

E1-E13

Form works shall include all temporary or permanent forms required for forming the concrete together with all temporary construction for their support.

Form works shall be designed and erected by the Contractor so that concrete can be properly placed and compacted in a manner that the hardened concrete conforms to the required shape, position, and level subject to the specified tolerances and standards of finish. It shall be assembled with adequate nails and /or nuts and bolts. It shall consist of wooden boards, sheet metals, and any other suitable material that prevent loss of grout when the concrete is vibrated.

Special care shall be taken to maintain the stability of the form works and the tightness of the joints particularly during concrete vibrating operations.

The formworks shall be as specified in the BOQ with adequate ribs for the beam, column and slabs. The Engineer shall approve the material and position of any ties passing through the concrete. The whole or part of the tie shall be capable of being removed such that any remaining part shall be embedded in the concrete by at least the specified thickness for reinforcement cover. Any holes formed by removal of ties shall be filled with concrete or mortar of approved composition.

Form works at top shall be provided where the slope of the formed surface exceeds one in four.

Before each concrete operation commences, form works shall be cleaned of all rubbish and other foreign particles.

Concrete operations shall not commence until the erected form works has been inspected and approved. The Contractor shall give at least 48 hours notice for such inspection. On rejection for any reason, the Engineer shall require another 48 hours to inspect the rectified errors. The inside surface of forms shall be coated with an approved material to prevent the adhesion of concrete. Such material shall be applied strictly in accordance with the manufacturer's instructions and shall not come in contact with the reinforcement or anchors.

Construction of Formwork

Joints in formwork for exposed faces shall, unless otherwise specified, be evenly spaced and horizontal or vertical and shall be continuous in a regular pattern.

All joints in formwork shall be water tight. Where reinforcement projects through formwork, the form shall fit closely round the bars.

Formwork shall be so designed that it may be easily removed from the work without damage to the faces of the concrete. It shall also incorporate provisions for making minor adjustments in position, if required, to ensure the correct location of concrete faces. Due allowance shall be made in the position of all formwork for movement and settlement under the weight of fresh concrete.

Surfaces at slopes less than 20° may be formed by screeding.

Surfaces at slopes between 20° and 30° shall generally be formed if

		<p>the Contractor can demonstrate to the satisfaction of the Engineer that such slopes can be screeded with the use of special screed boards to hold the concrete in place during vibration.</p> <p>Horizontal or inclined formwork to the upper surface of concrete shall be adequately secured against uplift due to the pressure of fresh concrete. Formwork shall also be tied down or otherwise secured against floating within the body of the concrete.</p> <p>The internal and external angles on concrete surfaces shall be formed with fillets and chamfers of the sizes shown on the Drawing unless otherwise instructed by the Engineer.</p> <p>Supports for formwork may be bolted to previously placed concrete provided the type of bolt used is acceptable to the Engineer. If metal ties through the concrete are used in conjunction with bolts, the metal left in shall not be close to the face of the concrete by less than 50mm.</p> <p>Formwork shall not be re-used after it has suffered damage which is sufficient to impair the finished surfaces of the concrete.</p> <p>Where circumstances prevent easy access within the form, temporary openings shall be provided through the formwork for cleaning and inspection.</p> <p>Shear keys of the size and shape as indicated on the Drawing shall be provided in all construction joints.</p> <p>Where pre-cast concrete elements are specified for use as permanent formwork, or proposed by the Contractor and agreed by the Engineer, they shall comply with the requirements of formwork as specified in the Specifications in respect of surface finish, strength and rigidity. Such elements shall be set true to line and level within the tolerances prescribed for the appropriate class of finish and fixed so that they cannot move when concrete is placed against them.</p> <p>Preparation of Formwork</p> <p>Before any reinforcement is placed into position within formwork, the latter shall be thoroughly cleaned and then dressed with a release agent. The agent shall be either suitable oil incorporating a wetting agent, an emulsion of water suspended in oil or low viscosity oil containing chemical agents. The Contractor shall not use an emulsion of oil suspended in water nor any release agent which causes staining or discolouration of the concrete, air holes on the concrete surface, or retards the set of the concrete or affects the strength of concrete.</p> <p>In order to avoid colour differences on adjacent concret surfaces, only one type of release agent shall be used in any one section of the works.</p> <p>In cases where it is necessary to fix reinforcement before placing formwork, all surface preparation of formwork shall be carried out before it is placed into position. The Contractor shall not allow reinforcement or pre-stressing tendons to be contaminated with formwork release agent.</p> <p>Before placing concrete all dirt, construction debris and other foreign matter shall be removed completely from within the placing area.</p> <p>Before concrete placing commences, all wedges and other adjusting</p>
--	--	---

devices shall be secured against movement during concrete placing and the Contractor shall maintain a watch on the formwork during placing to ensure that no movement occurs. If any movement noticed, the formwork shall be set right immediately.

Removal of Formwork

The Contractor shall give 24 hours notice of his intentions to strike any form works. Forms shall be removed without shock vibrations or other damage to the concrete.

Formwork shall be carefully removed without shock or disturbance to the concrete. No formwork shall be removed until the concrete has gained sufficient strength to withstand any stresses safely to which it may thereby be subjected.

The minimum periods which shall elapse between completion of placing concrete and removal of forms are given in Table and apply to ambient temperatures higher than 10°C. At lower temperatures or if cement other than ordinary Portland are involved, the Engineer may instruct longer periods.

Alternatively, formwork may be removed when the concrete has attained the strength set out in Table provided that the attained strength is determined by making test cubes and curing them under the same conditions as the concrete to which they refer.

Compliance with these requirements shall not relieve the Contractor of his obligation to delay removal of formwork until the removal can be completed without damage to the concrete.

If the Contractor wishes to strip formwork from the underside of arches, beams and slabs before the expiry of the period for supports set out above, it shall be designed so that it can be removed without disturbing the supports. The Contractor shall not remove supports temporarily for the purpose of stripping formwork and subsequently replace them.

As soon as the formwork has been removed, bolt holes in concrete faces other than construction joints which are not required for subsequent operations shall be completely filled with mortar sufficiently dry to prevent any slumping at the face. The mortar shall be mixed in the same proportions as the fine aggregate and cement in the surrounding concrete and with the same materials and shall be finished flush with the face of the concrete.

After removal of the formwork, the date of casting of concrete shall be marked on the surface of related concrete by water proof paint/marker for estimation of curing time.

Minimum Time for Form works

Form work	Normal Weather (days)	Cold Weather (days)	Strength to be attained
1. Vertical or near vertical faces of mass concrete	24 hours		0.2 fck

		2. Beam sides, walls and unloaded columns	48 hours	1.5:	0.3 fck
		3. Sofits of slabs and beams :			
		Spans up to 3m	4 days	7 days	fck
		Spans over 3m to 6m	11 days	17 days	fck
		<p>Measurement</p> <p>Except as stated below, formwork shall be measured in square meter of formwork actually in contact with the finished face of the concrete. No deduction shall be made in the measurement for openings, pipes, ducts and the like, provided that the area of each is less than 0.50 square meters. Unless otherwise stated, if the volume or area of concrete has not been deducted when measuring the concrete, formwork to form box or the void shall not be measured.</p> <p>Formwork required for lean concrete, to form construction joints and shear keys for future concrete and other construction surfaces shall not be measured and the costs shall be included in the rates for other work.</p> <p>Formwork to contraction and expansion joints shall be measured in square meter on one face only. The rates shall include for the costs stated below and for forming recesses for sealant and channels for grout.</p> <p>The measurement of formwork is inclusive of the measurement for formwork finished surface, shoring, staging, scaffolding and other accessories required for erection and removal of the formwork.</p> <p>Payment</p> <p>The formwork shall be paid as per the contract unit rate. The rates for formwork shall include the cost of submission of details, transportation and use of all materials for formwork, erection including provision of supports, fillets and chamfers 75 mm and less in width, bolts, ties, fixings, cutting to waste, drilling or notching the formwork for reinforcement where required, working around pipes, ducts, conduits and waterstops, temporary openings, cleaning, dressing, removal of formwork, filling bolt holes and any remedial work including all incidental works required to complete the work as per Specification.</p> <p>The payment for unformed surfaces of concrete shall be deemed included in the contract unit rate of the relevant concrete.</p>			

G. Door and Windows

<p>G1</p>	<p>Wooden frames</p>	<p>The contractor is to clear out and destroy or remove all cut and shavings and other wood waste from all parts of the building and the site generally, as the work progress and at the conclusion of the work.</p> <p><u>Carpentry:</u> All carpentry shall be executed with workmanship of the best quality. Scantling and boarding shall be accurately sawn and shall be of uniform width and thickness throughout. All carpenter's work shall be left with sawn surface except where particularly specified to be wrought.</p> <p>All carpenter's work shall be accurately set out in strict accordance with the drawings and shall be framed together and securely fixed in best possible manner with properly made joints. All necessary brads, sheet metal screws, etc. shall be provided as directed and approved.</p> <p><u>Joinery:</u> All joints shall be accurately set out on boards to full size for the information and guidance of the artisans before commencing the respective works, with all joints, iron work and other works connected therewith fully delineated. Such setting out must be submitted to the Engineer In-charge and approved before such respective works are commenced.</p> <p>All joiner's work shall be cut out and framed together as soon after the commencement of the building as is practicable, but is not to be wedged up or glued until the building is ready for fixing same. Any portions that warp, wind or develop shakes or other defects within six months after completion of the works shall be removed and new fixed in their place on contractor's own expense.</p> <p>All work shall be properly mortises, tenons, house, shouldered, dovetailed, notched, wedged, pinned, braided, etc., as directed and to the satisfaction of the consultants and all properly glued up with the best quality approved glue.</p> <p>Joints in joinery must be as specified or detailed, and so designed and secured as to resist or compensate for any stresses to which they may be subjected. All nails, springs, etc. are to be punched and puttied. Loose joints are to be made where provision must be made for shrinkage, glued joints where shrinkage need not be considered and where sealed joints are required. Glue for load-bearing joints or where conditions may be damp must be damp must be of the resin type. For non-load-bearing joints or conditions may be guaranteed casein or organic glues may be used. All exposed surfaces of joinery work shall be wrought and all arise "eased-off" by planing and sand papering to an approved finish suitable to the specified treatment.</p> <p><u>Dimensions:</u> Joinery shall hold up to the specified sizes and as measure.</p> <p><u>Fixing Joinery:</u> All beads, fillets and small members shall be fixed with round or oval brads on nails well punched in and stopped. All large members shall be fixed with brass screws, the heads let in and palette to match the grain.</p>
------------------	-----------------------------	---

		<p>Unless otherwise specified, plugs of external work shall be of hardwood; plugs for internal work may be of softwood. Holes for plugging must be made with a proper drilling tool and the holes completely filled with the plugging material.</p> <p>Unless otherwise specified all skirting, window, grounds and backings for same, fillets etc., shall be plugged at intervals not exceeding 600mm.</p> <p>Bedding Joinery:</p> <p>All door and window frames, sills, wooden bars etc., which are fixed to brickwork, concrete by means of grounds, lugs, etc., shall be bedded solid in mortar as previously described and pointed with a recessed joint 6mm deep to the approval of the Engineer In-charge.</p> <p>Plywood, Block boards, Chipboards and MDF board, shall be bonded with synthetic resin of "interior" type and sheet metal screws unless otherwise stated for the doors. Where stated to be "exterior" type, they shall be weatherproof.</p> <p>All exposed edges of block board and chipboard shall be lipped with hardwood as described below.</p> <p>Samples of all such materials and their source of manufacture must be approved by the Engineer In-charge before used in the works.</p> <p>Inspection and Testing</p> <p>The Engineer In-charge shall be given facilities for inspection of all works in progress whether in workshop or on site. All timber as it arrives on the site and not approved by them must be removed forthwith, failing which the Employer, with the advise of the Engineer In-charge, may arrange for the removal of the rejects and impose of them as they may consider advisable at the contractor's expenses.</p> <p>Notwithstanding approval having been given as above, any timber incorporated in the works found to be in any way defective before the expiry of the maintenance period shall be removed and renewed at the contractor's expense. The contractor is to allow for testing or prototypes of special construction units and the Engineer In-charge shall be at liberty to select any samples they may require for the purpose of testing i.e. for moisture content, or identification of species, strength, etc.</p> <p>Where timbers need to be extended into a wall, they shall be thoroughly "Brush Treated" with a wood preservative approved by the Engineer In-charge, and as much clear air space maintained around the timber where it adjoins the wall as possible.</p> <p>Measurement</p> <p>Measurement of works will be made in m³ of works as specified.</p> <p>Payment</p> <p>Payment for work will be made on the basis of contract unit price indicated in the BOQ.</p> <p>The payment will be full and final compensation for all material, labor, and equipment to complete the works as specified.</p>
--	--	--

G2	Panelled shutters	<p>The window shutters may be fully panelled, fully glazed, partly glazed and partly panelled, battened or Venetian as specified. Styles and panels shall be neatly planed and truly finished to exact dimensions. Styles and rails shall be framed properly and accurately with mortise and tenon joints and fixed with bamboo pins as per drawing. Glue shall be applied at all joints before clamping and fixing with bamboo pins. Panels shall be of one piece without any joints and shall be housed with 12.5mm insertion into rails and styles.</p> <p>Panels shall be of thickness as specified in the drawing. All rails above 100mm in width shall have double tenon. No tenon shall exceed 6mm the thickness of the member. In case of swing door, swing door hung in lace shall not be rebated together. It shall be fitted with vision panels.</p> <p>Measurement Measurement of works will be made in m2 of works as specified.</p> <p>Payment Payment for work will be made on the basis of contract unit price indicated in the BOQ.</p> <p>The payment will be full and final compensation for all material, labor, and equipment to complete the works as specified.</p>
G3 – G6, G8 – G14	Glazed, Ply, Teak, GI	<p>Shutter or frame shall be as described in Panelled doors.</p> <p>Putty: Putty for glazing in wood frames shall be composed of pure</p>

	<p>Sheet and Wire mesh Shutters</p>	<p>linseed oil and whiting powder free from grittiness.</p> <p>Wooden beads All wooden beads shall be from hard wood fitted against the glass. Wooden beads shall be bedded against the rebate and secured by 12.5mm glass nails fixed at 75mm apart. The rebate depth shall be 12.5mm Wooden beads shall not project beyond the rebate. All glass panes shall have edge-clearance, when fitted of 1.5mm all round.</p> <p>Beads shall be painted with approved paint before fixing glass pane.</p> <p>Hinges/ handles/bolts/screwes: The window shutters shall have minimum of two-piece 100mm steel hinges with steel screws, one aluminum handle and two pieces of 150mm tower bolts of super brand or equivalent with steel screws.</p> <p>The timber louvers shall be 12 mm. thick of the size and fixing as shown in the Drawing. Vertical slats if required shall be provided as per instruction of the Engineer.</p> <p>Construction Procedure</p> <p>The window shutters may be fully panelled, fully glazed, partly glazed and partly panelled, battened or Venetian as specified. Styles and panels shall be neatly planed and truly finished to exact dimensions. Styles and rails shall be framed properly and accurately with mortise and tenon joints and fixed with bamboo pins as per drawing. Glue shall be applied at all joints before clamping and fixing with bamboo pins. Panels shall be of one piece without any joints and shall be housed with 12.5mm insertion into rails and styles.</p> <p>Panels shall be of thickness as specified in the drawing. All rails above 100mm in width shall have double tenon. No tenon shall exceed 6mm the thickness of the member. In case of swing door, swing door hung in lace shall not be rebated together. It shall be fitted with vision panels.</p> <p>Rebates of metal frames receiving glass shall be prepared and treated with primer for putty prior to glazing and putty shall be primed ten days after glazing (See Painting).</p> <p>Glass louvers shall have ground edges and be fixed in accordance with the instruction of the louver frame manufacturer.</p> <p>Mirrors shall be 4mm S.G. silvered plate glass or Swan brand with polished edges, and shall be drilled for and fixed with four chromium plated screws with detachable dome heads.</p> <p>On completion remove all broken, scratched or cracked panes and replace with new to the satisfaction of the Engineer In-charge. Clean inside and out with approved cleaner. On no account shall scraping with glass clean windows.</p> <p>Solid core shutters</p> <p>Wooden solid core of lightwood with 4mm Teak plywood in both sides glued and lipped with mould salwood of sample approved by project engineer. The tolerances for the overall size are +-3mm +-1mm in thickness.</p> <p>Where described as "External Quality" flushes doors are to be finished with weatherproof plywood as before described and the Engineer In-charge must approve sample doors before the doors are completed. The door shutters are polished with clear chapra polish and painted with two coats of touch wood polish.</p>
--	--	--

		<p>The doors shall be stucked with moulding of approved design in the shape as shown in the drawing.</p> <p>The Door shutters shall have minimum of three pieces of 150mm brass hinges with brass screws, one IPSA Mortise lock of heavy duty or equivalent, two pieces of 150mm brass tower bolts of good quality with brass screws, 75 mm doorstopper.</p> <p>Construction Procedure</p> <p>The window shutters may be fully panelled, fully glazed, partly glazed and partly panelled, battened or Venetian as specified. Styles and panels shall be neatly planed and truly finished to exact dimensions. Styles and rails shall be framed properly and accurately with mortise and tenon joints and fixed with bamboo pins as per drawing. Glue shall be applied at al joints before clamping and fixing with bamboo pins. Panels shall be of one piece without any joints and shall be housed with 12.5mm insertion into rails and styles.</p> <p>Panels shall be of thickness as specified in the drawing. All rails above 100mm in width shall have double tenon. No tenon shall exceed 6mm the thickness of the member. In case of swing door, swing door hung in lace shall not be rebated together. It shall be fitted with vision panels.</p> <p>Measurement</p> <p>Measurement of works will be made in m2 of works as specified.</p> <p>Payment</p> <p>Payment for work will be made on the basis of contract unit price indicated in the BOQ.</p> <p>The payment will be full and final compensation for all material, labor, and equipment to complete the works as specified.</p> <p>NB: These specifications may be adopted for other type of shutters viz plywood, teak, GI sheet flush doors etc. as well. For such items replace glass with relevant material as specified.</p>
G7	MS Roding in window frames	As specified and instructed by the Engineer-in-Charge and detailed working drawings, if any.
G21	UPVC doors and windows	<p>Polyvinyl chloride Resin suspension grade is the basic raw material for forming PVC compound. PVC resin then is mixed with chemicals like Calcium, Stearate, Hydrocarbon Wax, Titanium Dioxide, Calcium Carbonate, and Acrylic processing aids. Further, additives like impact modifiers, pigments, epoxy plasticizer, UV stabilizer, lubricants, chemical blowing agent etc. are added. The purpose of adding the chemicals and additives is to impart cellular structure, strength, surface finish, colour and resistance to fading by light rays. These chemicals are mixed in the desired proportion and shall be used in the formulation of PVC material and for free and smooth extrusion of PVC profiles.</p> <p>The Upvc work as scheduled and detailed shall be fabricated as per the Drawings. Fabricated Upvc work covered by this specification shall be supplied and installed by the well-known local Upvc fabricators or manufacturer as approved by the Engineer.</p>

		<p>Before placing any orders the Contractor shall state the name of the window manufacturer he has selected from the list of approved manufacturers. The nominated manufacturer shall not be changed without prior approval of the Engineer.</p> <p>Manufacture Upvc work shall be fabricated in accordance with the standard Manufacturer manual and as per the Drawings showing jointing details, hardware and extrusion profiles. It will be the Upvc fabricator's responsibility to ensure that all fabricated Upvc work is carried out in accordance with the Drawings. The frame and the rebate shall be a monolithic unit. All the members shall be free of stains and any damage. If any damage or defects during delivery or after fitting in position are found, the defects shall be rectified immediately or replaced at the Contractor's expense. The Contractor shall attach all necessary product and quality specification along with the quotation. All the frames and shutters shall be of the same color.</p> <p>The fly mesh net: if applicable, shall be stainless steel jali (fly mesh net) or as approved by the A/E. The jali shall be fitted neatly and cleanly in the shutter and shall be tight and plain throughout the shutter. Any damage during fitting or delivery will not be accepted. The Contractor shall replace the fly mesh immediately at no additional cost if the fly mesh is found to be damaged after fitting and fixing in position.</p> <p>The contractor shall verify the exact dimension at site before fabrication. In the event of any changes, the Contractor shall be timely informed by the Upvc contractor (in the event of third party supply) at the time of masonry works. Any demolition and/or re-masonry work due to the lack of co-ordination between the Upvc contractor and the civil contractor will be the responsibility of the Contractor and it is incumbent on the Contractor to co-ordinate, as appropriate, with the UPVC.</p> <p>Workshop Drawings The contractor shall arrange for the preparation of complete workshop drawings of all fabricated Upvc work and shall submit same to the Engineer for approval.</p> <p>Flashing All flashings required to be built in as the work proceeds shall be supplied by the Contractor and built in by the trade concerned. All other flashings as detailed on the Drawings shall be supplied and fixed in position by the fabricator.</p> <p>Hardware Fittings Hinges, handles, knobs, locks, ball catchers, bolts, door stoppers, door closers, door spring adjustable shelf fittings and other hardware fittings for doors and windows shall be of the best quality and of the specified make and approved by the Engineer. The size number, make etc. shall be as per the hardware schedules as shown on drawings or BOQ.</p>
--	--	--

		<p>Measurements It shall be done in square meter of the area done.</p> <p>Rate Rate shall be for all labor and materials, accessories, all complete.</p>
H. Flooring Works		
H1	Concrete flooring	<p>Materials: Cement: Portland cement as per specification under "Concrete Work" Aggregate of 12mm nominal gauge shall be properly gauged. Sieving may be insisted upon in which case the contractor shall provide/ supply necessary sieves and labor at his own cost. Sand shall be clean inner bed. Grain distribution shall be same as described under 'Plastering'.</p> <p>Proportion: The concrete shall be either 1:2:4 mix or 1:4:8 mix or as specified in the drawing. All mix shall be batched by volume except cement, which shall be proportioned by weight and as specified.</p> <p>Mixing: Mixing shall be done on a watertight platform. Material shall be dry mixed after accurately gauging different materials in wooden boxes. The dry mixture shall be turned over thrice (at least) till the colour is uniform and then twice while wet. Water shall be added gradually and no more than necessary to sufficiently wet the materials. Only that much concrete shall be mixed which can be used within half an hour. Each stock of dry mix shall not be larger than consuming one bag of cement. In case of machine mixing IS. Code shall be strictly followed and the mixing done under the supervision of the site In-charge.</p> <p>Preparation of Sub-grade The sub-grade shall be cleared of all loose earth, rubbish, and other foreign matter. If necessary the sub-grade shall be cleaned with wire brushes. Cleaned sub-grade shall then be wetted with water thoroughly, but no water pool shall be allowed. Necessary slope shall be given in the sub-grade itself. If the sub-grade is of lean concrete the flooring shall be commenced within 48 hours.</p> <p>Placing Concrete shall be laid in horizontal layers and gently rammed.</p> <p>Finishing It shall be compacted first with wood float. The blows shall be fairly heavy but as consolidation takes place, light rapid strokes shall be given. Beating shall continue till all hollows in concrete are filled with mortar paste. Then the surface shall be trawled till the moisture disappears. The surface shall be checked with straight edge. The surface must be uniform in colour. Immediately after trawling, well-mixed neat cement slurry mixed integrally with hardening liquid 2 litres. to 50kg of cement shall be sprinkled in a uniform layer at the rate of 2.2 kg. per sq.m. The cement slurry shall be trawled smooth with a steel float several times till approved finish is achieved. The surface shall be without the float marks or air holes. Sample of</p>

		<p>workmanship shall be got to approved prior to work.</p> <p>Curing Curing shall not be commenced until the top layer has hardened. Hardened concrete shall be kept wet for 15 days. Covering with empty cement gunnies shall be avoided, as the colour is likely to be bleached with the remnants of cement matter from the bags</p> <p>Measurement It shall be measured in square meter for specified thickness measured from wall to wall exclusive of any finishing or as per instructions of Engineer.</p> <p>Unless otherwise stated in the schedule of quantities, nothing extra shall be admissible for small areas and corners and work in any shape. No deductions shall however, be made for protruding or independent columns occurring in the floors, door frames embedded in floor or any other part out when the area does not exceed 0.1 m² for each. However nothing extra shall be allowed for the cutting involved at such places.</p>
<p>H6, H25, H29, H39</p>	<p>Tiling</p>	<p>Tiles: The tile material for Glazed/Non-glazed Vitrified Porcelain (Granite Viglacera-Vietnam, Portebello- Brazil or equivalent make) / Glazed/Non-glazed Ceramic tiles (Somany, Kajaria or equivalent make), shall confirm to IS:777 (respective IS standards) or Equivalent approved by the Engineer</p> <p>The tiles shall be of approved colour, size and shape or as shown in the drawings. and shall be laid to the pattern approved by the Engineer. The tiles shall be of uniform colour, true to size and shape and free from cracks, twists, uneven edges, crazing and other defects. The size and thickness of the tiles shall be as specified. The contractor shall submit samples of tile for selection and approval by the Engineer In-charge and all tiles delivered to the site shall conform to the approved samples with regard to size, quality, texture and colour.</p> <p>Mixing: Mixing shall be done as per specification for mortar mixing of brick masonry work</p> <p>Preparation of Surface and installation Wall surfaces shall be brushed cleaned and wetted. Prior to installing any tile, the Contractor shall inspect surface and conditions in areas to receive tile work and shall notify the Engineer of any serious defects or conditions that will interfere with or prevent a satisfactory tile installation and shall coordinate with other traders of work.</p> <p>Approximately 12 mm thick level and plumb, scratch coat of cement mortar 1:4 or as specified by site engineer shall be applied. The scratch coat shall be moist cured for at least 24 hours before application of floating coat.</p> <p>Before applying floating coat the scratch coat shall be thoroughly wetted. The floating coat, plastic mix of neat cement of approximately 3 mm thickness shall be applied even with screeds to true plane. Floating coat shall be applied over areas no larger than can be covered with tile while the mortar is still plastic (half set).</p>

		<p>Glazed tile shall be soaked, completely immersed in clean water at least 30 minutes and drained. Individual tile that exhibits drying along edges shall be allowed to remain on the backs of tile at the time of setting.</p> <p>Tiles shall be installed by applying a skin coat of a plastic mix of neat cement to backs of tile and firmly pressing tile into the floating coat to true plane and position. White cement shall be used for the skin coat where white joints are required.</p> <p>During the process of setting tiles, continuous horizontal and vertical cuts every 40cm to 60 cm shall be made through the floating coat while plastic, using the point of a trowel turned edge wise, Care shall be taken to prevent cutting into the scratch coat.</p> <p>Where full size tile cannot be laid, it shall be cut (sawn) to required size and edges rubbed smooth to ensure a true and straight joint.</p> <p>All tile work finishing shall be adequately protected from damage during the progress of construction and any damage shall be repaired to the satisfaction of the Engineer at the Contractor's expense.</p> <p>Joints in Tile Work</p> <p>Joints in tile work shall be accurately aligned with horizontal joints level and vertical joints plumb. Joints shall be maintained uniformly wide by aligning spacer lugs on tile edges if tiles are so manufactured or by use of wetted strings.</p> <p>Tile Layout</p> <p>Tiles shall be laid out in such a way that no tile less than half size occurs. Where tile must be cut at edges or penetrated the cut edges shall be carefully filed and neatly ground. Chipped, cracked or broken tile shall not be used and all defective work shall be replaced and repaired to the satisfaction of the Engineer at the Contractor's expense.</p> <p>Grouting the Tile Joints</p> <p>After tiles have been set firm and strings removed, the tiles shall be dampened and joints grouted full with a plastic mix of neat cement by trowel, brush or finger application. Unless otherwise directed, grout shall be white cement. During grouting all excess grout shall be cleaned off the tile surface with damp cloth sponges</p> <p>The finished floor surface shall be true to required levels.</p> <p>All tile work finishing shall be adequately protected from damage during the progress of construction till completion and any damage shall be repaired to the satisfaction of the Engineer at the Contractor's expense. Upon completion prior to final inspection and acceptance, the Contractor shall clean all tile work. Acids or agents liable to damage the work shall be avoided. If tile surface show mass scratches, crack or other imperfections, which cannot be removed by cleaning; the Contractor shall remove the defective material and replace with new material at no additional expense. Sample of workmanship and tile grout proposed (silicone) shall be approved prior to execution of work</p> <p>Measurement</p> <p>The measurement shall be in square meters of the work done including the setting mortar. The rate shall be for the material and labor, all complete.</p>
--	--	---

H11	Telia brick pavement	<p>Telia tiles are to be uniform in size, shape and colour and free from twist and other defects, in every respect equal to samples to be deposited with and approved by the Engineer In-charge.</p> <p>Measurement Measurement of works will be made in m2 of plan area of works.</p> <p>Payment Payment for work will be made on the basis of contract unit price indicated in the BOQ. The payment will be full and final compensation for all material, labor, and equipment to complete the works as specified.</p>
H12, H15a	Flat Brick Soling	<p>The flat brick soling shall be made in foundation and floor. The brick laying/ soling shall be done over the 5cm sand filling in line and level Each brick shall be laid separately and tamped firmly in place in the sand bed. Joints between bricks shall be filled with dry sand. On completion the surface shall be true to line and level with no part deviating from true line and level by more than 20mm. No mud on sand filling shall be allowed when level is not maintained in excavation.</p>
H13, H15b, H17	Brick On Edge Soling	<p>The Brick on Edge brick soling shall be made in foundation and floor. The brick laying/ soling shall be done over the 5cm sand filling in line and level Each brick shall be laid separately and tamped firmly in place in the sand bed. Joints between bricks shall be filled with dry sand. On completion the surface shall be true to line and level with no part deviating from true line and level by more than 20mm. No mud on sand filling shall be allowed when level is not maintained in excavation.</p>
H19	Sand filling	<p>Sand filling in floor shall be done with proper ramming in 23mm layers, after sprinkling with water and consolidating. Sand shall be free from rubbish, organic materials etc. Particular care shall be exercised not to dump sand in space between foundation trench and inside face of the masonry. Measurement shall be in cu.m. of consolidated actual Work.</p>
	Brickbat Filling	<p>Brickbat boulders shall be hard, tough, sound and durable. No brickbat shall be more than 5cm. Boulders shall be laid in their natural bed. Smaller size boulders/pebbles shall be used to fill up gaps between boulders in order to form uniform well-knitted floor structure. Measurement shall be in cubic meter of actual length, breadth and depth.</p>

H20	Neat cement punning	Refer to plaster works, exclude sand.
H21	Wooden planking	<p>The seasoned and aldrin treated Timber Planks of finished size of 450mm x65mm x15mm of specified hardwood or as directed by the consultant shall be used and laid in approved type of pattern over levelled cement punned surfaces and fixed to the floor with Dendrite glue or water repellent Glue and each tile is screwed to ground with two nos. sheet metal screws and grip. At the edges, of floor the plank should have minimum of 8mm gap for the expansion and contraction. The top surface shall be finished in perfect line and level.</p> <p>The planks shall be painted with chapra paints as per the specifications and finished with 2 coats of Polyurethane paints as wearing coat. The texture of the floors shall be in mat or as instructed by the Project In-charge.</p>
H22, H23	Concrete interlocking tiles	<p>The cement concrete interlocking tiles of approved shape size and color shall be provided in cement sand mortar. These shall be either pre-cast concrete blocks or cast-in-situ concrete. Cement sand mortar used for bedding and joint shall be in 1:4 ratio.</p> <p>Laying</p> <p>The tiles shall be laid on either concrete or compacted sand-gravel as indicated in the Drawing.</p> <p>In the case of cement sand base , it shall be 1 part cement; 4 parts sand and mixing shall be done as per specification for mortar mixing of brick masonry work laid to the dimensions, lines and levels shown in the Drawing and well compacted by ramming or other means. Before laying the foundation of lean concrete, the base shall be leveled and slightly watered to make it damp.</p> <p>In the case of sand gravel it shall consist of a material approved by the Engineer. The tiles shall then be laid out and bedded on 12 mm thick cement sand mortar of 1:4 ratios. The gaps between the block/slabs shall not be more than 12 mm and shall be filled with 1:4 cement sand mortar.</p> <p>Tests and Standard of Acceptance</p> <p>Concrete shall be tested in accordance with specification for concrete and shall meet the specified criteria. All tiles shall be laid true to the lines and levels shown on the Drawing or as instructed by the Engineer.</p> <p>Measurement</p> <p>The work shall be measured in square meter of the area. Concrete and/or sand-gravel foundation shall be measured in cubic meters. Excavation for foundation shall not be measured. It is deemed included in the measurement of the tiles.</p> <p>Payment</p> <p>The tiles measured as above shall be paid at the contract unit rate which shall be the full and the final compensation to the Contractor. Concrete and/or sand-gravel foundation shall be paid for separately, as provided under respective Sections of these Specifications.</p>

H24	Plaster of Paris works	<p>The plaster of Paris shall be of semi – hydrate variety calcium sulphate. Its fineness shall be such that when sieved through a sieve of IS sieve designation 3.35mm for 5 minutes, after drying the residue left on it shall be not more than 1% by weight. It shall not be too quick setting. Initial setting time shall not be less than 13 minutes.</p> <p>Preparation of Surface Projecting burrs of mortar formed during existing cement plaster shall be removed. The surface shall be scrubbed clean with wire brushes. In addition the plastered surface shall be pock marked with pointed tool, at spacing of not more than 4cm centers and depth of pocks to be approx. 3mm deep. This is to ensure a proper key for the plaster. The surface shall be cleaned of oil and grease marks etc.</p> <p>Application The material shall be mixed with water to a workable consistency. Plaster of Paris shall be applied directly on the wall plasters in suitable size panels and finished to a smooth surface by a steel trowels. The plaster shall be applied in such a manner that it fully fills the gaps the thickness over the plastered surface is as specified in the description of the item. The finished surface shall be smooth and true to plane, slopes or curves as required.</p> <p>Measurement Measurement shall be in square meter of area of application. Rate shall include materials, mixing, laying, curing, finishing and labor etc. all complete.</p>
H25	Clay tiling	Refer to glazed tiling works
I. Plaster, Punning and Pointing Works		
I1 – I7, I13 - I16	General Plaster Works	<p>Plastering shall be started from top and worked down. All putlog holes shall be properly filled in advance of the plastering as the scaffolding is being taken down. Wooden screeds 75 mm wide and of the thickness of the plaster shall be fixed vertically 2.5 to 4 meters apart to act as gauges and guides in applying the plaster. The mortar shall be laid on the wall between the screeds using the plaster's float and pressing the mortar so that the raked joints are properly filled. The plaster shall then be finished off with a wooden straight edge reaching across the screeds. The straight edge shall be worked on the screeds with a small upward and sideways motion 50 mm or 75 mm at a time. Finally, the surface shall be finished off with a plaster's wooden float. Metal floats shall not be used.</p> <p>When recommencing the plastering beyond the work suspended earlier the edges of the old plaster shall be scraped, cleaned and wetted before plaster is applied to the adjacent areas.</p> <p>No portion of the surface shall be left out in a condition to be patched up later on.</p> <p>The plaster shall be finished to a true and plumb surface and to the proper degree of smoothness as required by the Engineer.</p> <p>The average thickness of plaster shall not be less than the specified thickness. The minimum thickness over any portion of the surface shall not be less than the specified thickness minus 3 mm.</p>

	<p>Any cracks which appear in the surface and all portions, which sound hollow when tapped, or are found to be soft or otherwise defective, shall be cut out in rectangular shape and re-done as directed by the Engineer.</p> <p>The surface to be plastered shall be brushed clean mortar joints of brick masonry or hollow concrete walls or any other surface to be plastered shall be raked to a depth of approximately 12mm, and the surface brushed down with a stiff brush and thoroughly wetted. The surface shall be free of all dust, loose materials, grease etc.</p> <p>The mortar shall be first dry mixed, by measuring with boxes to required proportion, and then water added slowly and gradually and mixed thoroughly to uniform consistency.</p> <p>The thickness of the plaster shall not be less than 12 mm not more than 20mm. In case of plaster thicker than 20mm, it shall be built by two or more coats each coat not exceeding 12mm in thickness.</p> <p>Cement shall be as specified above.</p> <p>Sand shall be as before specified but shall be graded to a suitable fineness in accordance with the nature of the plaster, etc., in order to obtain the finish required.</p> <p>Lime for plastering shall be as before described in clause 414 and slaked and run at least four weeks before use.</p> <p>All other mixes shall be constructed in a like manner.</p> <p>Moist curing shall be accomplished by keeping the plaster uniformly damp by suitable means. Moist curing shall start during application and continue for not less than 7 days.</p> <p><u>Hacking</u></p> <p>Prices of all paving and plastering etc. shall include for hacking concrete ceilings, beams, floors etc., by approved means and for raking out joints of walls 12mm deep to form a proper key. Plastering on walls generally shall be taken to include flush faces of lintels etc., in same.</p> <p>Surfaces to be paved or plastered must be brushed clean and well wetted before each coat is applied. All cement plaster shall be kept continually damp in the interval between application of coats and for seven days after application of the final coat.</p> <p>Dubbing out where required shall be composed of similar material to that following.</p> <p>Partially or wholly set material will not be allowed to be used or re-mixed.</p> <p><u>Samples</u></p> <p>The Contractor shall prepare sample square meter of the plastering and paving as directed until the quality, texture and finish required is obtained and approved by the Project Engineer after which all plastering or paving executed shall conform with the respective approved sample. No payment shall be accounted for such sampling.</p> <p><u>Finish</u></p> <p>Care shall be taken to insure that finished plaster surfaces shall be plumb, square, straight and true to line.</p> <p>Generally all screeds and paving shall be finished smooth, even and truly level (unless specifically required to falls and currents, etc.), and paving shall be steel troweled or floated.</p>
--	---

		<p>Rendering and plastering shall be finished plumb, square, smooth and even.</p> <p>All surfaces to be plastered shall be thoroughly wetted before any plastering is commenced and the Contractor shall allow in his prices for dusting external angles with neat cement to give additional strength.</p> <p>No plastering will be allowed to take place until all chases for service have been cut, services installed and chases made good. On no account may finished plaster surface be chased and made good.</p> <p>All Work shall be to approval and any not complying with the above shall be hacked away and replaced, as directed, and at the Contractor's expense.</p> <p><u>Arises and Angles in Plastering</u></p> <p>All arises shall be clean and sharp or slightly rounded as directed including neatly forming miters.</p> <p>All making good shall be cut out to a rectangular shape, the edges undercut to form dovetail key and finished flush with face of surrounding plaster. All cracks, blisters and other defects must be cut out made good and the whole of the paving and plastering Work left perfect on completion.</p> <p>Screeds shall be in cement and sand (1:4) and rates shall include for thoroughly hacking, cleaning and soaking the receiving structure in water. No creed shall be laid on a dry structure in any circumstances. Where changes of floor finish occur they shall be divided by strips as specified.</p> <p>The Contractor's special attention is drawn to the fact that all screeds, immediately after the initial set has taken place, will be required to be continuously covered in water by the sand trap or other approved method for at least 10 days. Any screed panel that is found to be dry before the end of this period shall be removed at the discretion of the Project Engineer.</p> <p>Waterproofed external rendering shall consist of minimum 12mm cement and sand (1:4) rendering at the rate of 2.05 litre to 41 kgs of cement all in accordance with the manufacturer's instructions and finished perfectly true and even with a wood float.</p> <p><u>External Plastering and Rendering:</u></p> <p>Waterproofed External Plaster or Rendering work shall consist of minimum 12.5mm to 16mm as detailed in the Bill of Quantity with cement/ sand ratio 1:3 or 1:4 at the rate of 1/2 gallon to 90 lbs of cement all in accordance with the manufacturer's instructions and finished perfectly true and even with a wood float.</p> <p><u>Internal Plastering and Rendering:</u></p> <p>Internal Plastering or Rendering shall consist of minimum 12.5mm to 16mm as detailed in the Bill of Quantities with cement/ sand ration 1:3, 4 finished perfectly true and even with a wood float.</p>
--	--	---

<p style="text-align: center;">18 – 112</p>	<p style="text-align: center;">General Pointing Works</p>	<p>For pointing, the mortar shall be filled and pressed into the raked out joints, before giving the required finish. The pointing shall then be finished to proper type given on the Drawing. If type of pointing is not mentioned on the Drawing the same shall be ruled pointing. For ruled pointing after the mortar has been filled and pressed into the joints and finished off level with the edges of the bricks, it shall while still green be ruled along the centre with a half round tool of such width as may be specified by the Engineer. The superfluous mortar shall then be cut off from the edges of the lines and the surface of the masonry shall also be cleaned of all mortar.</p> <p>Where external faces of the mortared masonry work will be backfilled or otherwise permanently covered up, the mortared joint shall be finished flush to the faces of the adjacent stonework.</p> <p>Where mortared masonry faces will remain exposed, the mortar joints shall be pointed to a consistent style as shown on the Drawing. Pointing shall be carried out using mortar 1:3 by volume of cement and sand or as shown on the Drawing. The mortar shall be filled and pressed into the raked out joints before giving the required finish. The pointing, if not otherwise mentioned, shall be ruled type for which it shall, while masonry work is still green, be ruled along the centre with half round tools of such width as may be specified by the engineer. The excess mortar shall, then, be taken off from the edges of the lines and shall not be unnecessarily plastered over the exposed stone works. The thickness of the joints shall not be less than 3mm for Ashlar masonry.</p> <p>Before applying the punning and pointing, the base surface shall be cleaned, any dust or loose particles removed and thoroughly wetted. The surface shall be free of all dust, loose materials, grease etc. The average thickness of the punning and pointing work shall not be less than 3 mm. The pattern shall be as per instruction of the Engineer or as shown in the drawings.</p> <p>The mortar shall be first dry mixed, by measuring with boxes to required proportion, and then water added slowly and gradually and mixed thoroughly to uniform consistency.</p> <p>The coat shall be finished by rubbing with a steel trowel and any depression shall be filled in and rubbed to shining surface.</p> <p>Cement shall be as specified above.</p> <p>Sand shall be as before specified but shall be graded to a suitable fineness in accordance with the nature of the plaster, etc., in order to obtain the finish required.</p> <p>All other mixes shall be constructed in a like manner.</p> <p>Moist curing shall be accomplished by keeping the plaster uniformly damp by suitable means. Moist curing shall start during application and continue for not less than 7 days.</p> <p>Measurement Measurement of works will be made in m2 of works as specified.</p> <p>Payment Payment for work will be made on the basis of contract unit price indicated in the BOQ.</p> <p>The payment will be full and final compensation for all material, labor, and equipment to complete the works as specified.</p>
--	--	---

J. Paint Works

J1 – J29

General

All materials shall be delivered on site intact in the original drums or tins and shall be mixed and applied strictly in accordance with the manufacturer's instructions and to the approval of the Engineer. All cement paints and washable distemper shall be applied by brush; emulsion paints shall be applied by means of a brush then rolled. All enamel paints are applied by brush or sprayed, and bitumen and bituminous base aluminum paints are applied by brush. Before application of any paint, adjoining surfaces shall be covered by cloth, or paper and wherever paints stains it shall be removed before leaving the work in same day.

The only addition, which will be allowed to be made locally will be liquid thinners supplied or recommended by the manufacturers and none shall be, thinned more than approved by the Engineer.

Preparation and priming of surfaces:

Concrete and Cement rendered surfaces shall be smooth and free from defects and shall be allowed to dry out thoroughly. Surfaces shall be thoroughly brushed down and left free from all efflorescence, dirt and dust.

All such surfaces, which are to be finished with oil or enamel paint, shall be primed with two coats of alkali resisting primer.

Plaster surfaces shall be perfectly smooth and free from defect. All such surfaces shall be allowed to dry for a minimum period of four weeks. Surfaces shall be stopped with approved plaster compound, rubbed down flush, thoroughly brushed down and left free from all efflorescence, dirt and dust.

Fair-faced surfaces shall be dry, brushed down and free from dust or dirt and shall be treated with an approved alkali resisting primer (for plastic emulsion).

Metal work generally shall be thoroughly wire brushed to remove all scale, rust, and through sand papering shall be done before any painting is done. Where severe rust exists, the special anti-rust primer must be used. After painting it shall be stored in covered shed and 60cm above ground.

Shop primed surfaces shall have bare places touched up with an approved metal primer.

Un-primed surfaces shall be given one coat of primer as last.

Galvanized surfaces, which are thoroughly weathered, shall be, brushed down with white spirit, washed down and given one coat of zinc chromate primer.

Bituminous-coated surfaces shall be given as isolating coat of shellac knotting followed by an approved metal primer.

Woodwork generally shall be rubbed down, given one coat shellac knotting, one coat wood self knotting primer, and all cracks, nail holes, defects, and uneven surfaces, etc., stopped and faces up with hard stopping rubbed down flush.

Before oiling woodwork all stains must be removed and uniform colour obtained and filled.

COLOURS AND PRIMING:

		<p>The priming undercoats and finishing coats shall each be of differing tints and the priming and undercoats shall be of the correct types and tints to suit the respective finishing coats in accordance with the following instructions. All finishing coats shall be of colours and tints selected by the Engineer. The paintwork shall have a uniform finish and all paint for external work shall be exterior quality only.</p> <p>Rubbing Down: Each coat of paint shall be properly dried and shall be well rubbed down with fine glass paper before the next coat is applied. The paintwork shall be finished smooth and free from brush marks. Samples Cards of all paints, etc., shall be submitted to and samples prepared for approval of the Engineer before laying on and such samples, when approved, shall become the standard for work.</p> <p>Program: The contractor shall so arrange his program of work that all other Trades are completed and away from the area to be painted when the painting begins.</p> <p>Ironmongery, Protection and Cleaning Up: All ironmongery shall be removed from joinery before painting is commenced and shall be cleaned and renovated if necessary and re-fixed after completion painting. Cover up all floors, etc., with non-resinous sawdust or other approved covering when executing and all painting decorating work. Paint splashes, spots and stains shall be removed from floors, woodwork, etc., and damaged surface touched up and the whole of the work left clean upon completion.</p> <p>Materials: All paint materials of specified brand shall be obtained from the manufacturer or authorized dealer. All sealers, primers and undercoating are to be obtained from the makers of the finishing materials and are to be in accordance with their recommendation for the particular finish required.</p> <p>Knot Sealer: For use on knots and resinous portions of woodwork. Stopping and Filling composed of parts putty to one part of stiff white lead.</p> <p>Lacquer: Approved polyurethane eggshell clear lacquer applied in accordance with the manufacturer's instructions. Polish shall be an approved brand of wax polish. Oil shall be best quality linseed oil. Filler for polished or oiled surfaces to be Beeswax filler.</p> <p>Wood Preservative: All wood work, as specified or instructed shall, be treated after cutting and preparation but before assembly or fixing with three coats of solution consisting of one part of Atlas "A" wood preservative brown grade to three parts of water. The solution is to be brushed in all faces of all timbers unless exposed to view and painted. This is applicable in the wood frame contact with masonry and roof purling, batten and counter rafter.</p>
--	--	--

		<p>The contractor shall note that this solution is HIGHLY POISONOUS and shall take all necessary precautions and instruct his workmen accordingly.</p> <p>Paint Application: Painting Items as described hereafter shall comprise the following, and shall all include for preparing and priming surfaces as above described: - Cement Paint : Apply two coats. Plastic Emulsion : Apply a minimum of three coats, using a thinning medium or water only if and as recommended by the manufacturer. An approved plaster primer tinted to match may be substituted for the first coat. Paint : Apply two undercoats and one finishing coat of enamel gloss oil paint. Flat oil paint : Apply two coats of flat oil paint, using thinning medium in accordance with the manufacturer's instructions. Oil : Apply two coats of linseed oil. Wax Polish : Apply a minimum of two coats to approval. Lacquer : Apply three coats of Polythene lacquer as described, to approval. Prime : Prepare and prime only before fixing.</p> <p>Moulded cornices and coves. (a) Length shall be measured at the centre of the girth. (b) Moulded cornices and coves shall be given in square metres the area being arrived at by multiplying length by the girth. (c) Flat or weathered top to cornices when exceeding 15 cm in width shall not be included in the girth but measured with the general plaster work. (d) Cornices which are curved in their length shall be measured separately.</p> <p>If the old Paint of existing surface is firm and sound, it shall be cleaned of grease, smoke etc. The surface shall then be rubbed down with sand paper and dusted. Rusty patches shall be cleaned up and touched with synthetic enamel paint. If the old Paint is blistered and flaked, it shall be completely removed.</p> <p>Measurement: Measurement shall be in square meters of the actual covered area of the paints. Nothing extra shall be allowed for painting any rough surface. The rate shall include for specified coats inclusive of materials, labor, scaffolding all complete.</p>
<p>J1, J2, J13</p>	<p>White wash</p>	<p>For whitewashing, wherever scaffolding is necessary, it shall be erected on double supports tied together by horizontal pieces, over which scaffolding planks shall be fixed. No ballies, bamboos or planks shall rest on or touch the surface which is being white washed. For all exposed brick work or tile work, double scaffolding having two sets of vertical supports shall be provided. The supports shall be sound and strong, tied together with horizontal pieces over which scaffolding planks shall be fixed. Where ladders are used, pieces of old gunny bags shall be tied on their tops to avoid damage or scratches to walls.</p>

		<p>For white washing the ceiling, proper stage scaffolding shall be erected.</p> <p>Preparation of Surface Before new work is white washed, the surface shall be thoroughly brushed free from mortar droppings and foreign matter. In case of old work, all loose particles and scales shall be scrapped off and holes in plaster as well as patches of less than 50 cm area shall be filled up with mortar of the same mix. Where so specifically ordered by the Engineer-in-Charge, the entire surface of old white wash shall be thoroughly removed by scrapping. Where efflorescence is observed the deposits should be brushed clean and washed. The surface shall then be allowed to dry for atleast 48 hours before white washing is done.</p> <p>Preparation of Lime Wash The lime wash shall be prepared from fresh stone white lime. The lime shall be thoroughly slaked on the spot, mixed and stirred with sufficient water to make a thin cream. This shall be allowed to stand for a period of 24 hours and then shall be screened through a clean coarse cloth. 40 gm of gum dissolved in hot water, shall be added to each 10 cubic dicimetre of the cream. The approximate quantity of water to be added in making the cream will be 5 litres of water to one kg of lime. Indigo (Neel) upto 3 gm per kg of lime dissolved in water, shall then be added and stirred well. Water shall then be added at the rate of about 5 litres per kg. of lime to produce a milky solution.</p> <p>Application The white wash shall be applied with moonj brushes to the specified number of coats. The operation for each coat shall consist of a stroke of the brush given from the top downwards, another from the bottom upwards over the first stroke, and similarly one stroke horizontally from the right and another from the left before it dries. Each coat shall be allowed to dry before the next one is applied. Further each coat shall be inspected and approved by the Engineer-in-Charge before the subsequent coat is applied. No portion of the surface shall be left out initially to be patched up later on. For new work, three or more coats shall be applied till the surface presents a smooth and uniform finish through which the plaster does not show. The finished dry surface shall not show any signs of cracking and peeling nor shall it come off readily on the hand when rubbed. For old work, after the surface has been prepared, a coat of white wash shall be applied over the patches and repairs. Then a single coat or two or more coats of white wash as stipulated in the description of the item shall be applied over the entire surface. The white washed surface should present a uniform finish through which the plaster patches do not appear. The washing on ceiling should be done prior to that on walls.</p> <p>Protective Measures Doors, windows, floors, articles of furniture etc. and such other parts</p>
--	--	---

		<p>of the building not to be white washed, shall be protected from being splashed upon. Splashings and droppings, if any shall be removed by the contractor at his own cost and the surfaces cleaned. Damages if any to furniture or fittings and fixtures shall be recoverable from the contractor.</p> <p>Measurements Length and breadth shall be measured and area shall be calculated in sqm. Measurements for Jambs, Soffits and Fills etc. for openings shall be as described in plaster. Cornices and other such wall or ceiling features, shall be measured along the girth and included in the measurements. The number of coats of each treatment shall be stated. The item shall include removing nails, making good holes, cracks, patches etc. not exceeding 50 sq. cm. each with material similar in composition to the surface to be prepared.</p> <p>Rate The rate shall include all material and labor involved in all the operations described above.</p>
J3	Distemper works	<p>Washable distemper of required colour as approved by the Engineer shall be used, conform to IS: 427-latest revision. Before application of the distemper the shade shall be approved by the Engineer. The paint (SKK-Japanese, Nerolac, Berger or equivalent) shall be water based washable distemper as per NS, IS specification. Only fresh distemper shall be used, hard or set shall not be used.</p> <p>Preparation of Paint The washable distemper powder shall be stirred slowly in clean water using 0.6 litre of water per kg of distemper or as specified by the manufacturer. Warm water shall preferably be used. It shall be allowed to stand for at least 30 minutes (or if practicable over night) before used. The mixture shall be well stirred before and during use to maintain an even consistency. Distemper shall not be mixed in larger quantity than is actually required for one day's work.</p> <p>Preparation of Surface Before new work is distempered, the surface shall be thoroughly brushed free from mortar dropping and other foreign matter and sand papered smooth. New plaster surfaces shall be allowed to washable for at least six weeks before applying distemper. Pitting in plaster shall be made good with plaster of Paris mixed with the colour to be used. The surface shall then be rubbed down again with fine grade sandpaper and made smooth. A coat of distemper shall be applied over the patches. The patched surface shall be allowed to washable thoroughly before the regular coat of distemper is applied.</p> <p>Application For new work, the treatment shall consist of a priming coat of whitening followed by the application of two or more coats of distemper till the surface shows and even colour. For each coat, the entire surface shall</p>

		<p>be coated with the mixture uniformly with proper distemper brushes in horizontal strokes followed immediately by vertical ones, which together shall constitute one coat.</p> <p>The subsequent coats shall be applied only after the previous coat has dried. The finished surface shall be even and uniform and shall show no brush marks.</p> <p>Enough distemper shall be mixed to finish one room at a time. The application of a coat in each room shall be finished in one operation and no work shall be started in any room, which cannot be completed the same day. After each day work, the brushes shall be washed in hot water and hung down to washable. Old brushes, which are dirty or caked with distemper, shall not be used.</p> <p>On plastered, POP surface (paint shall be prepared with sand papering), putting, and two coats of primer. The paint is applied in two coats of washable distemper with roller or brush. The surface should be properly cleaned and treated with water based primer as per manufacturer's specifications. Rectification of defects in plaster/POP with broken edges should be done by using a proper colour putty, paste as per manufactures specifications.</p> <p>The surface on which paint is applied shall become hard washable in 16 hours. The necessary single / multistage scaffoldings required for the work shall be provided as detailed out under coatings. The equipment, roller or brush used on the work should be immediately washed with water to facilitate future use.</p> <p>Measurement</p> <p>Measurement shall be in square meters of the actual covered area of the paints. Nothing extra shall be allowed for painting any rough surface e.g. external sand - faced plaster or work in short width or surface in any shape. The rate shall include for two or more coats inclusive of materials, labor, scaffolding all complete.</p>
<p>J4</p>	<p>Water proof cement paint works</p>	<p>Cement paint of required colour shall be of ready mixed type in sealed container of approved brand (Snowcem India Ltd., or equivalent brand or manufacture)r conforming to IS: 5410 - latest revision, approved by the engineer in sealed tins, shall be used. Before application of the cement paint the shade shall be approved the Engineer. It shall be procured either in 50 kg. Container or 25 kg. Container. All such container shall have unbroken seal with manufacturer's name and trade marks as well as a description of contents all clearly marked. Such paint shall be mixed and applied strictly in accordance with the manufacturer's instructions and with the approval of site In-charge. All materials shall be stored in dry place.</p> <p>Preparation of Paint</p> <p>Only fresh cement paint shall be used, hard or set paint shall not be used. The container shall be made loose by rolling and shaking the container before opening. Cement paint shall be mixed with water in two stages.</p>

		<p>First a paste shall be prepared by mixing 2 parts of cement paint powder with one part of water by volume and immediately this shall be thinned by adding another part of water to have uniform solution of consistency of paints. Care shall be taken to add the cement paint gradually to the water and not vice versa.</p> <p>The second stage shall comprise of adding further one part of water to the mix and stirring thoroughly to obtain a liquid of workable and uniform consistency. In all cases the manufacturer's instructions shall be followed meticulously.</p> <p>Cement paint shall be mixed in such quantities as can be used up within an hour of its mixing as otherwise the mixture will set and thicken affecting flow and finish. The lids of cement paint shall be kept tightly closed when not in use, as by exposure to atmosphere the cement paint rapidly becomes air set due to its hygroscopic qualities.</p> <p>Preparation of Surface</p> <p>Before application of paint all dust and foreign materials shall be removed from the surface by use of wire brush. All holes, cracks and abrasion shall be fill with plaster of Paris, properly prepared and applied and smoothed off to match adjoining surfaces. Any loose or uneven areas or any major cracks or defects in the concrete or plaster back ground shall be cut out and made good and the repairs allowed to dry thoroughly. Any efflorescence shall be removed by dry brushing The surface shall be allowed to run off.</p> <p>Application</p> <p>The fresh mixed paint shall be frequently stirred during application and no mixture (paint) shall be used after an hour of mixing. A vertical stroke with another horizontal stroke shall be termed one coat. Paint solution shall be applied to the surface with hair brushed/roller in a number of coats to get uniform finish. After the first coat of the paint has hardened, it shall be cured with water at least for 24 hours before the second coat is applied. Similarly required number of coats shall be given to get an even and uniform shade. It shall be kept damp at least for seven days. Sample of workmanship shall be approved by the Engineer prior to commencement of work.</p> <p>The final painted surface shall exhibit uniform and good finished appearance. Measurement shall being square meter of actual covered area. No extra shall be allowed for scaffolding, curing and painting corners, plaster strips etc.</p> <p>Measurement / Payment</p> <p>Measurement shall be in square meters of the actual covered area of the paint. Nothing extra shall be allowed for painting any rough surface e.g. external sand - faced plaster or work in short width or surface in any shape. The rate shall include for two or more coats inclusive of materials, labor, scaffolding all complete.</p>
--	--	---

<p>J5 a, J15 - J17</p>	<p>Enamel Paints</p>	<p>The primer and paint shall be of approved quality and of approved manufacture like Asian Paints, Nerolac, Jensolin, Berger British Paints India Ltd., Johnson and Nicholson, India or equivalent brand approved by the Engineer. These materials shall be ready mixed and in sealed tins with manufacturer's name, colour and instruction clearly painted in the container.</p> <p>Preparation of Surface</p> <p>All surfaces to be painted shall be planed and thoroughly sand papered, first by using No. 120 sandpaper. Ordinary putty shall fill up nail holes, cracks or other inequalities. Putty shall be made up of 2 parts of best quality whiting (absolutely dead stone lime) 1 part of white lead mixed together in linseed oil and kneaded (3 oz. of linseed oil to 1 lb. of whiting).</p> <p>A primer coat shall be locally applied in holes, cracks etc. before putty is applied. The putty/paste fillers shall be of approved quality and manufacture and shall be applied to the surface with a knife or other sharp edged tools after the priming coat as well as after each undercoat. After the surface is dry, it shall be sand papered by using No. 60 sandpaper.</p> <p>Surface so prepared shall be painted with one coat of primer. The primed surface when dry shall be sand papered by using No. 100 sand paper.</p> <p>The primed surface so prepared shall be painted with one coat of selected enamel using bristle brush and not horsehair ones. The paint shall be applied in thinnest possible layers with parallel strokes</p> <p>Care shall be taken to ensure the surface being free from dust or other foreign material before priming or enamelling the surface. No paint shall splash on the floor, wall jambs, sill or other part of the building.</p> <p>Application</p> <p>On Wood work</p> <p>After preparing and after the priming coat has been applied a topcoat shall be applied.</p> <p>The primed surface so prepared shall be painted with one coat of selected enamel using bristle brush and not horsehair ones. The paint shall be applied in thinnest possible layers with parallel strokes.</p> <p>Another coat shall be applied after the previous coat is dry. Care should be taken that dust or other foreign materials do not settle or otherwise disfigure the various coats. The same brand of materials will be used for various coats. The paint shall be used and applied as per manufacture's printed instruction. The paints shall be applied with bristle brushes and not horse hair ones. The paints shall be applied in the thinnest possible layers with parallel drawings, no flowing down shall be allowed. Painting to false ceiling and acoustic materials such as thermo Cole, perforated acoustic tile, soft board etc. shall be done by spray painting only. The Engineer prior to commencement of work shall approve sample of workmanship.</p>
----------------------------	----------------------	---

		<p>On metal surface</p> <p>The paint shall be continuously stirred in the container so that its consistency is kept uniform throughout.</p> <p>The painting shall be laid on evenly smoothly by means of crossing and laying - off. The crossing and laying off consists of covering the area with paint, brushing the surface hard for the first time and then brushing alternatively in opposite directions, two or three times and then finally brushing lightly in a direction at right angles to the same. In this process no brush marks shall be left after the laying – off if finished. The full process of crossing and laying - off will constitute one coat. Where so stipulated, the painting shall be carried out using spray machines suited for the nature and location of the work to be carried out. Only skilled and experienced workmen shall be employed for this class of work. Paints used shall be brought to the requisite consistency by adding suitable thinner. Spraying shall be carried out only in dry conditions. No exterior painting shall be done in damp foggy or rainy weather. Surface to be painted shall be clean, dry, smooth, and adequately protected from dampness. Each coat shall be applied in sufficient quantity to obtain complete coverage, shall be well brushed and evenly worked out over the entire surface and into all corners, angles and crevices allowed to thoroughly dry. Second coat shall be of suitable shade to match final colour, and shall be approved by the Engineer before final coat is started. Allow at least 48 hours drying time between coats for interior and 7 days for exterior work, and if in the judgement of the Engineer more time is required it shall be allowed.</p> <p>Finished surfaces shall be protected from dampness and dust until completely dry. Finished work shall be uniform, of approved colour, smooth and free for runs, sags, defective brushing and clogging. Make edges of paints adjoining other materials of colours sharp and clean, without overlapping.</p> <p>Finish:</p> <p>The painted surfaces shall present uniform appearance and semi – glass finish free from steaks, blisters etc.</p> <p>Measurement</p> <p>Measurement shall be in square meters of the actual covered area. Nothing extra shall be allowed for painting any rough surface e.g.</p>
--	--	---

		external sand - faced plaster or work in short width or surface in any shape. The measurement shall be as follows:																																
		<table border="1"> <thead> <tr> <th>Description of Work</th> <th>Measurement Method</th> <th>Overlapping Factor</th> </tr> </thead> <tbody> <tr> <td>Panelled or Framed</td> <td rowspan="7">Measured flat (not girthed) end of frame to frame.</td> <td>1.5 for each side</td> </tr> <tr> <td>Ledged & Battened</td> <td>1(1/8) for each side.</td> </tr> <tr> <td>Flush</td> <td>1 for each side.</td> </tr> <tr> <td>Fully glazed or gauged</td> <td>0.5 for each side.</td> </tr> <tr> <td>Part panelled and part</td> <td>1 for each side.</td> </tr> <tr> <td>Fully ventilated or Louvered</td> <td>1.5 for each side.</td> </tr> <tr> <td>Boarding with covered fillet and match boarding</td> <td>1.5 for each side.</td> </tr> <tr> <td>Tile & slate battening</td> <td rowspan="2">Measured flat (no deduction for open spaces)</td> <td>3/4 for overall</td> </tr> <tr> <td>Trellis or Jaffri</td> <td>1 for Painting all over</td> </tr> <tr> <td>Gates and open palisade fencing including standard braces, rails, stays</td> <td>The height shall be taken from the lower end of the palisade up to the top of the palisade but not to the standards if they are higher.</td> <td>1 for Painting all over</td> </tr> <tr> <td>Carved or enriched work</td> <td>Measured flat</td> <td>1.5 for each face.</td> </tr> <tr> <td>Corrugated sheet.</td> <td>Measured flat</td> <td>114% of flat area</td> </tr> </tbody> </table>	Description of Work	Measurement Method	Overlapping Factor	Panelled or Framed	Measured flat (not girthed) end of frame to frame.	1.5 for each side	Ledged & Battened	1(1/8) for each side.	Flush	1 for each side.	Fully glazed or gauged	0.5 for each side.	Part panelled and part	1 for each side.	Fully ventilated or Louvered	1.5 for each side.	Boarding with covered fillet and match boarding	1.5 for each side.	Tile & slate battening	Measured flat (no deduction for open spaces)	3/4 for overall	Trellis or Jaffri	1 for Painting all over	Gates and open palisade fencing including standard braces, rails, stays	The height shall be taken from the lower end of the palisade up to the top of the palisade but not to the standards if they are higher.	1 for Painting all over	Carved or enriched work	Measured flat	1.5 for each face.	Corrugated sheet.	Measured flat	114% of flat area
Description of Work	Measurement Method	Overlapping Factor																																
Panelled or Framed	Measured flat (not girthed) end of frame to frame.	1.5 for each side																																
Ledged & Battened		1(1/8) for each side.																																
Flush		1 for each side.																																
Fully glazed or gauged		0.5 for each side.																																
Part panelled and part		1 for each side.																																
Fully ventilated or Louvered		1.5 for each side.																																
Boarding with covered fillet and match boarding		1.5 for each side.																																
Tile & slate battening	Measured flat (no deduction for open spaces)	3/4 for overall																																
Trellis or Jaffri		1 for Painting all over																																
Gates and open palisade fencing including standard braces, rails, stays	The height shall be taken from the lower end of the palisade up to the top of the palisade but not to the standards if they are higher.	1 for Painting all over																																
Carved or enriched work	Measured flat	1.5 for each face.																																
Corrugated sheet.	Measured flat	114% of flat area																																
		The rate shall include for specified coats inclusive of materials, labor, scaffolding, all complete																																
J11, J12, J22, J23	Red Lead Primer	Red Lead primer paint shall be of approved brand. The lead content in the paint shall be less than 60% by weight. The site in charge shall examine the paints before seal is broken																																

<p style="text-align: center;">J29</p>	<p style="text-align: center;">Anti Termite Treatment</p>	<p>Prevention of the termite from reaching the super-structure of the building and its contents can be achieved by creating a chemical barrier between the ground, from where the termites come and other contents of the building which may form food for the termites. This is achieved by treating the soil beneath the building and around the foundation with a suitable insecticide.</p> <p>Materials</p> <p>Chemicals: Any one of the following chemicals in water emulsion to achieve the percentage concentration specified against each chemical shall be used:</p> <p>(i) Chlorphriphos emulsifiable concentrate of 20%</p> <p>(ii) Lindane emulsifiable concentrate of 20%</p> <p>To achieve the specified percentage of concentration, Chemical should be diluted with water in required quantity before it is used. Graduated containers shall be used for dilution of chemical with water in the required proportion to achieve the desired percentage of concentration. .</p> <p><i>Safety Precautions</i> : Chemical used for antitermite treatment are insecticides with a persistent action and are highly poisonous. This chemical can have an adverse effect upon health when absorbed through the skin, inhaled as vapours or spray mists or swallowed. The containers having emulsifiable concentrates shall be clearly labeled and kept securely closed in stores so that children or pet cannot get at them. Storage and mixing of concentrates shall not be done near any fire source or flame. Persons carrying out chemical soil treatments should familiarize themselves and exercise due care when handling the chemicals whether in concentrated or in diluted form. After handling the concentrates or dilute emulsion, worker shall wash themselves with soap and water and wear clean clothing especially before eating and smoking. In the event of severe contamination, clothing shall be removed at once and the skin washed with soap and water. If chemical has splashed into the eyes, they shall be flushed with plenty of soap and water and immediate medical attention shall be sought. The use of chemical shall be avoided where there is any risk of wells or other water supplies becoming contaminated.</p> <p>Treatment</p> <p>Treatment along outside of foundations: The soil in contact with the external wall of the building shall be treated with chemical emulsion at the rate of 7.5 litres per square metre of vertical surface of the sub-structure to a depth of 300 mm. To facilitate this treatment, a shallow channel shall be excavated along and close to the wall face. The chemical emulsion shall be directed towards the wall at 1.75 litres per running metre of the channel. Rodding with 12 mm diameter mild steel rods at 150 mm apart shall be done in the channel. If necessary, for uniform dispersal of the chemical to 300 mm depth from the ground level. The balance chemical of 0.5 litre per running metre shall then be used to treat the backfill earth as it is returned to the channel directing the spray towards the wall surface.</p>
---	--	--

	<p>If there is a concrete or masonry apron around the building, approximately 12 mm diameter holes shall be drilled as close as possible to the plinth wall about 300 mm apart, deep enough to reach the soil below and the chemical emulsion pumped into these holes to soak the soil below at the rate of 2.25 litres per linear metre.</p> <p>In soils which do not allow percolation of chemicals to desired depth, the uniform disposal of the chemical to a depth of 300 mm shall be obtained by suitably modifying the mode of treatment depending on site condition.</p> <p>In case of RCC foundations the soil (backfill) in contact with the column sides and plinth beams along with external perimeter of the building shall be treated with chemical emulsion at the rate of 7.5 litres/sqm. of the vertical surface of the structure. To facilitate this treatment, trenches shall be excavated equal to the width of the shovel exposing the sides of the column and plinth beams upto a depth of 300 mm or upto the bottom of the plinth beams, if this level is less than 300 mm.</p> <p>The chemical emulsion shall be sprayed on the backfill earth as it is returned into the trench directing the spray against the concrete surface of the beam or column as the case may be.</p> <p>Treatment of Soil under Floors : The points where the termites are likely to seek entry through the floor are the cracks at the following locations:</p> <ul style="list-style-type: none"> (a) At the junction of the floor and walls as result of shrinkage of the concrete; (b) On the floor surface owing to construction defects; (c) At construction joints in a concrete floor, cracks in sections; and (d) Expansion joints in the floor. <p>Chemical treatment shall be provided in the plinth area of ground floor of the structure, wherever such cracks are noticed by drilling 12 mm holes at the junction of floor and walls along the cracks on the floor and along the construction and expansion joints at the interval of 300 mm to reach the soil below. Chemical emulsion shall be squirted into these holes using a hand operated pressure pump to soak the soil below until refusal or upto a maximum of one litre per hole. The holes shall then be sealed properly with cement mortar 1:2 (1 cement: 2 coarse sand) finished to match the existing floors. The cement mortar applied shall be cured for at least 10 days as per instruction of Engineer-in-charge.</p> <p>Treatment of Voids in Masonry : The movement of termites through the masonry wall may be arrested by drilling holes in masonry wall at plinth level and squirting chemical emulsions into the holes to soak the masonry. The holes shall be drilled at an angle of 45 degree from both sides of the plinth wall at 300 mm intervals and emulsion squirted through these holes to soak the masonry using a hand operated pump. This treatment shall also be extended to internal walls having foundations in the soil. Holes shall also be drilled at wall corners and where door and window frames are embedded in the masonry or floor at ground. Emulsion shall be squirted through the holes till refusal or to a maximum of one litre per hole. Care shall be taken to seal the holes after the treatment.</p>
--	---

		<p>Treatment at Points of Contact of Wood Work : The wood work which has already been damaged beyond repairs by termites shall be replaced. The new timber shall be dipped or liberally brushed at least twice with chemical in oil or kerosene. All existing wood work in the building which is in contact with the floor or walls and which is infested by termites, shall be treated by spraying at the points of contacts with the adjoining masonry with the chemical emulsion by drilling 6 mm holes at a downward angle of about 45 degree at junction of wood work and masonry and squirting chemical emulsion into these holes till refusal or to a maximum of half a litre per hole. The treated holes shall then be sealed. Infested wood work in chaukhats, shelves, joints, purlins etc., in contact with the floor or the walls shall be provided with protective treatment by drilling holes of about 3 mm diameter with a downward slant to the core of the wood work on the inconspicuous surface of the frame. These holes should be at least 150 mm centre to centre and should cover in entire frame work. Chemicals shall be liberally infused in these holes. If the wood is not protected by paint or varnish two coats of the chemicals shall be given on all the surfaces and crevices adjoining the masonry.</p> <p>Measurement Measurement shall be in square meter of applied surface of total plinth area, flat measurement only and</p> <p>Rate Rate shall be inclusive of all labor and materials.</p>
K. Damp Proof Works		
K1, K2	Concrete DPC	<p>The damp proof course shall consist of cement, sand/stone aggregate mixed with 2% of Accoproof, Impermo or Cement seal by weight of cement and painted with two coal tar paint over it. Damp proof Course will be provided to all walls, which do not have tie beam above ground level as per the details of the working drawing.</p> <p>Water Proofing Compound Integral cement water proofing compound conforming to IS 2645 and of approved brand and manufacture, enlisted by the Engineer-in-Charge from time to time shall be used.</p> <p>The contractor shall bring the materials to the site in their original packing. The containers will be opened and the material mixed with dry cement in the proportion by weight, recommended by the manufacturers or as specifically described in the description of the item. Care shall be taken in mixing, to see that the water proofing material gets well and integrally mixed with the cement and does not run out separately when water is added.</p> <p>Cement shall be fresh Portland cement. Sand shall be clean course of 5mm size and down free from mica and clay. Stone aggregate shall be hard and tough of 12.mm size well graded and free from dust and dirt. Water proofing compound other than Accoproof, Impermo or Cement seal may be used after obtaining permission from the site-in- charge regarding the acceptability of the compound and quantity required for desired result.</p>

		<p>Cement shall be thoroughly mixed with required 2%by weight of waterproofing compound, and then mixed dry with the required volume of sand to make a proportion of 1:2. The cement sand mix shall then be thoroughly mixed dry with stone aggregate to maintain required proportion. Clean water shall then be mixed gradually to give a plastic mix of required consistency. The mixing shall be done by turning at least three times to give uniform and homogeneous concrete.</p> <p>All the mixing shall be done in an impervious masonry platform. Before lying concrete, the level of the surface of the plinth shall be checked longitudinally and transversely. All joints shall be raked and surfaces moisten by pouring clean water on it. The inside of the formwork shall be covered with polyethylene sheet so as to make water- tight joint between the formwork and the concrete.</p> <p>Concrete shall be laid uniformly by tamping to make dense concrete, leveled both transversely and longitudinally.</p> <p>The damp proof course shall be laid continuously except across doorways. Construction joints if unavoidable shall be given at the site of doors or wall opening. Such joints shall be sloped, and such sloped surface shall be applied with neat cement wash before starting concerning on following days. Hardened concrete shall be cured for 15 days. Shuttering may be removed after 72hours.</p> <p>Two coats of hot coal tar shall be applied on the cured cement concrete. The first coat shall be applied at 1.5 Kg. per sq. and the paint shall be blinded immediately with coarse sand and the surface is tamped lightly. Second coat of hot coal tar shall be applied at the rate of 1 Kg. per sq. uniformly over the surface. Such surface shall be immediately blinded with coarse sand and tamped lightly. Lay over the full width of the walls and at the height shown on the drawings a mortar screed of sufficient thickness to form a level surface and cover the screed with two coats of hot bitumen.</p> <p>Measurement Measurement of works will be made in m³ of works as specified.</p> <p>Payment Payment for work will be made on the basis of contract unit price indicated in the BOQ. The payment will be full and final compensation for all material, labor, and equipment to complete the works.</p>
K3	Bitumen Paint	Refer tarfelt works below
K4	Polythene Sheet	To be approved by the Engineer-in-Charge

<p>K5 – K6</p>	<p>Tarfelt</p>	<p>Prior to the laying of the roofing materials on the slope or flat roofs, one layer of finished underlay shall be provided on thin news paper sheets. The underlay shall work as the false ceiling for the room as well as shall act as the water-sealing agent to the room. This is achieved through the following:</p> <p>Waterproof and Termite resistant Plywood: Kit Plywood of Phenol Bonded, hot pressed and termite resistant special plywood with manufacturer's guarantee towards their reliability to the specifications, of the kind, as per the Indian Standards. The sizes and the thickness shall be as per the detail designs and as specified in the bill of quantities. Samples of the materials and their manufacturer's warranty card shall be submitted for Project In-charges approval.</p> <p>Tarfelting and Bitumen Paints: Tar felt: Shalimar Tar felt or equivalent shall be according to IS. Tar felt supplied should be packed in rolls with IS Certification mark. Tar felt shall be free from visible external defects, such as holes, oil patches, ragged or untrue edges, breaks, cracks, tears, protuberances and indentations. Unless otherwise stated, tar felt supplied shall be in widths of 90 cm and 100cm and generally in lengths of 10m and 20m. The sample should be submitted to the Engineer In-charge before bulk purchase, and should be approved by him.</p> <p>Bitumen Mastic: Shall be of approved quality conforming to IS: 3037-1965. This shall be supplied in sealed tins with IS Certification mark.</p> <p>Laying: The felt shall be laid in lengths at right angles to the direction of the run off gradient, with paper or plastic barrier between tar felt and concrete, commencing at the lowest level and working up to the crest such that the overlaps of the adjacent layers of felt offers the minimum obstruction to the flow of water. In the next layer, mastic asphalt or bitumen is spread, and tar felt is laid. The tar felt laid should be in three layers.</p> <p>The bitumen mastic (binding material) shall be prepared by heating to the correct working temperature and conveyed to the point of work in a bucket or pouring can. Each coat of each bay shall be spread evenly and uniformly by means of a float to the recommended thickness, on to the previously prepared surface, the isolating membrane or the preceding coat. Each coat of bitumen mastic shall be followed, without delay by the succeeding, since exposure to contamination (by dust or dirt) might impair adhesion and cause blistering. The finished floor shall not sound hollow when tapped with wooden mallet.</p> <p>The tar felt before laying shall be first cut to the required lengths, cleaned of dusting materials and laid out flat on roof. Each length of felt prepared for laying shall be laid in position and rolled up for a distance of half of its length. The hot binding material shall be poured on to the roof across the full width. In case of rolled felt, the felt is steadily rolled out and pressed down. The excess bonding material is</p>
-----------------------	-----------------------	---

		<p>squeezed out at the ends and is removed as the laying spreads. When the first half of the strip of felt has been bonded to the roof, the other half shall be rolled up and then unrolled on to the hot bonding material in the same way. Minimum overlap at the ends and the sides of strips of felt shall not be less than 15cm. All overlaps shall be firmly bonded with hot bitumen. The laying of second layer of felt shall be so arranged that the joints be staggered with those of the layer beneath it.</p> <p>Measurement Measurement of all the works will be made in m2 of works as specified.</p> <p>Payment Payment for work will be made on the basis of contract unit price indicated in the BOQ. The payment will be full and final compensation for all material, labor, and equipment to complete the works as specified.</p>
K7	Elastomeric water Proofing	<p>Providing and applying of two component acrylic polymer modified cementations flexible membrane system (Perma guard, Aquafin 2K/M or equivalent) as approved by engineer, on RCC rooftop, basements, terraces and sunken slabs etc including injection system (pressure grouting) on water leakage area and new & old concreting joint where necessary and filling Perma bond SBR modified mortar or equivalent on junction between floor and parapet wall area with "V" shape groove cutting as specified by the site engineer all complete:</p> <p>Measurement / Payment Measurement shall be in square meter of exact length and breadth. Rate shall include materials, mixing, laying, curing, finishing and labor etc., all complete.</p> <p>Note: The installation specifications for the approved material if different, the manufacturers specification shall be followed after site engineer's approval. Technical specification from manufacturer and the warranty provision/document shall be submitted to the site engineer before approval by the contractor.</p>
K8	Semi flexible polymer coating system	<p>Providing and applying 2 coat waterproofing coating system for protecting concrete and masonry on RCC roof top, basements slabs, terrace and sunken slabs area over the entire surface including surface preparation, pipe lines and other joints</p> <p>2 coat shall be applied by brush at the ratio of 1:2 (Perma Bond AR / Shield liquid/ tapecrete P 151 and fresh grey cement powder) or as approved by site engineer according to respective manufacturers specification</p> <p>Materials: Approved polymer materials from manufacturer (Tapecret P 151, Perma Bond AR/ Perma Shield or equivalent) as approved by site engineer shall be applied.</p> <p>Technical specification from manufacturer and the warranty provision / document shall be submitted to the site engineer by the contractor.</p>

		<p>Mixing:- The polymer shall be mixed with neat cement in the ratio of 2 part cement: 1 part polymer by weight. The mixture has to be stirred thoroughly until no air bubbles remain in the mix. Any lump found in the mix should be removed.</p> <p>Surface preparation: The surface shall be cleaned to remove all dust, foreign matters, loose materials and any deposits of contamination which could affect the bond between the surface and the waterproofing coating. By scarifying, grinding, water blasting, sand blasting, acid washing or other approved method.</p> <p>New flat surface like sub base concrete shall be made reasonably smooth so as not to impede the application of the waterproofing coating and to avoid sharp projection. All concrete shall be thoroughly pre-wetted for at least prior to the application of the coating by pouring water on flat surface or by vigorously spraying water on vertical/ inclined surfaces.</p> <p>Depressions shall be filled and levelled after engineers approval</p> <p>Application:- The mix shall be applied in 2 coats by brush on rendered and / or prepared surface. First coat should be allowed to stir dry for 5-6 hours. The coatings shall be applied in uniform thickness to horizontal and vertical surfaces. The surface should be made wet before application in case of porous structure.</p> <p>Curing and Protection The surface after application shall be kept moist for a period of 2-3 days. Curing shall be started as soon as the chemical has hardened sufficiently so as not to be damaged by a fine water spray.</p> <p>After application of final coat, initial air drying shall be done for 2-6 hours. During this period no water is to be used for curing. In case of high temperature and low humidity combined with high wind condition, the coating shall be covered with polythene sheet to avoid rapid drying of the coating.</p> <p>After maximum period of 6 hours of the final application, moist curing shall be done for next 24 hours by way of spraying water on the coating. During the period at no point of time should the coating be left completely dry or submerged in water.</p> <p>During the first 12 hours of curing, the work shall be protected from abrasion, rain, and other adverse conditions. After moist curing, the coating shall be allowed to air dry for 3 days before submersion in water if required for use.</p> <p>The finished coat shall be tough, hard-wearing surface with waterproofing and shall allow trapped vapour to escape preventing peeling and blister formation.</p> <p>Measurement / Payment Measurement shall be in square meter of exact length and breadth. Rate shall include materials, mixing, laying, curing, finishing and labor etc., all complete.</p>
--	--	--

	<p>Integral water proofing treatment system:</p>	<p>Providing and applying powder or liquid waterproofing compound (Perma Trik/ Perma Plast-o-proof or equivalent) as approved by engineer as integral part of concreting system or plaster as specified by the site engineer all complete:</p> <p>Mixing:- The compound shall be mixed with cement in the ratio as specified in BOQ or as instructed by site engineer.</p> <p>Liquid compound: (Perma plast-o- proof or equivalent): 100 ml per 50 bags of cement)</p> <p>Powder form: (Perma Trik or equivalent) 500 gm per 50 kg bag of cement)</p> <p>The mixture shall be thoroughly mixed. Application, curing and protection shall comply with the concreting or plastering works under respective specification.</p> <p>Note: The installation specifications for the approved material if different, manufacturer's specification shall be followed after site engineers approval. Technical specification from manufacturer and the warranty provision/document shall be submitted before approval to the site engineer by the contractor.</p> <p>Measurement / Payment Measurement shall be as specified in BOQ . Rate shall include material and labor cost.</p>
<p>L. Maintenance and Dismantling Works</p>		
<p>L1, L2, L14, L15, L16</p>	<p>Dismantling Masonry Works</p>	<p>The Contractor shall dismantle any cement masonry works as indicated in the Drawings or as ordered by the Engineer. The resulting material shall be the property of the Employer and all suitable materials shall be stockpiled for reuse purposes within a lead of 30 m as directed by the Engineer. Unsuitable material shall be disposed off as directed by the Engineer.</p> <p>Cement masonry dismantling shall include use of labor and proper equipment, transporting, stockpiling and all incidental and provisions necessary to complete the work.</p> <p>The Contractor shall dismantle any dry stone masonry wall as indicated in the drawings or as instructed by the Engineer. The resulting material shall remain the property of the Employer and all suitable material shall be stockpiled for reuse purposes within a lead of 30 m as directed by the Engineer.</p>
<p>L3, L4</p>	<p>Dismantling Concrete Works</p>	<p>The Contractor shall dismantle any plain or reinforced concrete works as indicated in the Drawings or as ordered by the Engineer. The resulting material shall remain the property of the Employer and all suitable materials shall be stockpiled for reuse purposes within a lead of 30 meter. Unsuitable material shall be disposed off as directed by the Engineer.</p> <p>Concrete/reinforced concrete dismantling shall include use of labor and proper equipment, transporting, stockpiling and all incidental and provisions necessary to complete the work.</p>

L17	Wood works	The Contractor shall dismantle any wood works as indicated in the drawings or as instructed by the Engineer. The resulting material shall remain the property of the Employer and all suitable material shall be stockpiled for reuse purposes within a lead of 30 m as directed by the Engineer.
L19	Fence, Post, steel works	The Contractor shall dismantle any steel works as indicated in the drawings or as instructed by the Engineer. The resulting material shall remain the property of the Employer and all suitable material shall be stockpiled for reuse purposes within a lead of 30 m as directed by the Engineer
	Crack Treatments:	<p>Minor Crack: Providing and applying water proof mortar (Perma bond SBR mortar or equivalent.) on the RCC slab minor crack making "v" shaped groove cutting and polymer coating of 1 feet wide area from groove all complete.</p> <p>Major crack: Providing and filling seal (Perma poly seal or equivalent) on the RCC slab major crack with making "V" shaped groove cutting with primer coat all complete.</p> <p>Note: The installation specifications for the approved material if different, manufacturers' specification shall be followed after site engineer's approval. Technical specification from manufacturer and the warranty provision/document shall be submitted to the site engineer before approval by the contractor.</p> <p>Measurement / Payment Measurement shall be in running meter of exact length. Rate shall include materials, mixing, laying, curing, finishing, and labor etc., all complete</p>
	Injection/Pressure Grouting treatment	<p>Providing and applying pressure grouting by injection system with mixing integral waterproofing compound (Perma grout - 500, Aquafin - IB2..... or equivalent) as approved by engineer with fresh cement slurry on RCC basement slab, Water tank and RCC Shear wall area, including providing and filling Perma bond SBR modified mortar or equivalent on junction between concrete construction joint with "V" shape groove cutting including 15 mm dia pipe inserts at 1 x 1 m centre to centre as specified by the site engineer all complete:</p> <p>Application: Application shall be as per manufacturer's specification after approval by site engineer. Technical specification from manufacturer, the warranty provision and document shall be submitted to the site engineer by the contractor. Any flaws and defects shall be repaired at contractor cost and shall be submitted in clean flaw less condition.</p> <p>Measurement / Payment Measurement shall be in square meter of exact length and breadth.</p> <p>Rate Rate shall include materials, mixing, laying, curing, finishing and labor etc., all complete.</p>
M. Metal, Fence and railing Works		

<p>M1- M5,</p>	<p>Fabrication of MS Members</p>	<p>The Mild steel (MS) products including collapsible gates are fabricated from the Mild Steel flat, angle and channels conforming to the BS 15 or equivalent. The welding shall be butt-welding. The grips are of plastic or metal. The screws shall be steel screws. The product is primed with two coats of red lead primer.</p> <p>Measurement The work shall be measured in m² of opening in vertical plan or in unit weight as specified in the Bill of Quantity.</p> <p>Payment Payment for the work will be made on the basis of contract unit price indicated in the BOQ. The payment will be full and final compensation for all material, labor, and equipment to complete the works as specified.</p>						
<p>M6</p>	<p>Rolling Shutter</p>	<p>These shall consist of MS laths 1.25mm thick and 80mm wide laths or as specified. The laths shall be machine rolled and straightened with an effective bridge depth of 16mm and shall be interlocked together throughout their entire length and jointed together at the end with end locks. These shall be mounted on specially designed pipe shaft. Each lath section shall be continuous single strip piece without any joint.</p> <p>The springs shall be coiled type. The spring shall be manufactured from high tensile spring steel wire or strip of adequate strength to balance the shutters in all positions. The spring pipe shaft etc. shall be supported on strong mild steel brackets.</p> <p>Guide Channel The guide channels shall be of mild steel deep channel section and of rolled, pressed or built up (fabricated) construction. The thickness of the sheet used shall not be less than 3.15mm.</p> <p>The minimum depths for guide channels shall be as follows:</p> <table border="0" data-bbox="553 1056 1242 1144"> <tr> <td>Clear width of shutter</td> <td>Depth of Guide Channel.</td> </tr> <tr> <td>Up to 3.5m</td> <td>60mm</td> </tr> <tr> <td>3.5m and above</td> <td>75mm</td> </tr> </table> <p>The gap between the two legs of the guide channel shall be sufficient to allow the free movement of the curtain and at the same time - close enough to prevent the rattling of the curtain due to wind.</p> <p>Each guide channel shall be provided with a minimum of three fixing elates or supports for attachment to the walls or column by means of bolts or screws. The spacing of cleats shall not exceed 0.75m. Alternatively, the guide channels may also be provided with suitable dowels, hooks or pins for embedding in the walls.</p> <p>The guide channels shall be attached to the jambs, plumb and true, either in the overlapping fashion, projecting fashion or embedded in grooves, depending on the method of fixing.</p> <p>The cover of shaft, spring etc. shall be of the same material as that of lath.</p> <p>Fixing Brackets shall be fixed on the lintel or under the lintel as specified with rawl plugs, and screws bolts etc. the shaft along with the spring shall then be fixed on the brackets.</p>	Clear width of shutter	Depth of Guide Channel.	Up to 3.5m	60mm	3.5m and above	75mm
Clear width of shutter	Depth of Guide Channel.							
Up to 3.5m	60mm							
3.5m and above	75mm							

		<p>The lath portion (shutter) shall be laid on ground and the side guide channels shall be bound with it with ropes etc. the shutter shall then be placed in position and top fixed with pipe shaft with bolts and nuts. The sides guide channels and the cover and frame shall then be fixed to the walls through the plate welded to the guides. These plates and bracket shall be fixed by means of steel screws bolts, and rawl plugs drilled in the wall. The plates and screws bolts shall be concealed in plaster to make their location invisible. Fixing shall be done accurately in a workman like manner that the operation of the shutter is easy and smooth.</p> <p>Painting All surfaces are to be painted with primer coat and minimum two coats of enamel paints as per specification, after drying and thoroughly cleaned to remove all loose scale and loose rust. Surfaces not in contact but inaccessible after shop assembling, shall receive the full-specified protective treatment before assembling.</p> <p>Measurement & Rate The measurement shall be done in height multiplied by width of the shutter, i.e. in Sqm. No extra will be paid for like shutter cover box, edges, etc. The rate shall be inclusive of labor, material, all complete.</p>
M8	MS Gate	<p>The Mild steel gates are fabricated from the Mild Steel flat, angle and channels conforming to the BS 15 or equivalent. The welding shall be butt-welding conforming relevant clause of this specification The grips are of plastic or metal. The screws shall be steel screws. The gate shall of steel sheet conforming to BS 15 or equivalent of 20G.</p> <p>The gate is primed with two coats of red lead primer. The gate is painted with two coat of enamel of bituminous aluminum paint to get uniform painted surfaces.</p> <p>Measurement The above work shall be measured in m² of opening in vertical plan completed as specified.</p> <p>Payment Payment for the work will be made on the basis of contract unit price indicated in the BOQ. The payment will be full and final compensation for all material, labor, and equipment to complete the works as specified.</p>
M10, M12, M13	Fence Works	<p>The barbed wire fences shall be two-strand galvanized barbed wire (Minimum of 100gm/m²) over the Mild steel wires of required diameter should be used for fencing. The Mild Steel should conform BS 15 or equivalent. The concrete in concrete post shall conform to the design drawings.</p> <p>Construction Procedures The concrete posts are erected over the foundation. The barbed wire is tightened to the post in the hooks. A tension not exceeding 400 kg/m² is applied while erecting the wires in layers as per the design. At the end diagonal bracing shall be made.</p> <p>Testing and Inspection The erected fencing shall deform any post and wires shall be straight with out sagging.</p>

		<p>Measurement The above work shall be measured in m² of fence in vertical plan above the foundation completed as specified.</p> <p>Payment Payment for the work will be made on the basis of contract unit price indicated in the BOQ. The payment will be full and final compensation for all material, labor, and equipment to complete the works as specified.</p>
N. Ceiling, Wall Paneling and Partition Works		
	General	<p>The material for installing false ceiling system shall be made of appropriate board with flexural strength not less than 485 N cross directional and 175 N machine directional, with hardness at core, end and edge not less than 65 N, with capacity to withstand breaking load not less than 556 N in longitudinal direction and not less than 275 N in transverse direction. The thermal resistance value "R" shall be not less than 0.45, with fire propagation index "I" not less than 2.1. It shall be fixed to the underside of the suspended grid comprising properly placed at maximum distance 457mm c/c frame. Connecting clip and softie cleat using standard screw and proper metal grip, as per drawing, manufacturers' specification, and instruction of engineer, all complete.</p> <p>Finish The ceiling boards free of damages are fixed to the framing in perfect line and level. The joints are sealed with plaster of Paris and non-woven paper tapes with out forming any bubble the joints shall be finished flush to make the ceiling in one piece. The finished surface shall be smooth and true to plane and curved as required. Once laying of ceiling is completed the dust and floors are cleaned for the painting works.</p> <p>Measurement It shall be measured flat in square meter of the actual area covered.</p> <p>Payment Payment for work will be made on the basis of contract unit price indicated in the BOQ. The payment will be full and final compensation for all material, labor, and equipment to complete the works as specified.</p>
N10 N11	Gypsum Board	<p>9.5 mm-12mm thick (or as specified) Gypsum board tiles of 610 x 610 mm size (or as per design) conforming to IS 2095: 1982 & 2542-1981. The tiles shall be plain, textured or designed with design patterns as per drawings or approved by site engineer.</p> <p>The suspenders are galvanized mild steel straps of 28G and horizontal and transverse members are galvanized mild steel channel of 16 G. Construction Procedures</p> <p>Frame Work The frame work shall be of zinc coated mild steel or galvanized iron (G.I. framing) and shall consist of 45 mm sq. or 50 x50 mm square tubes of 18G as main runners as specified in the item at specified spacing welded together with 45 mm x 45 mm zinc coated Gyp steel</p>

		<p>branded channels, or 50 x 50 mm G.I. channels of 18G as runners at specified spacing. The above frame shall be suspended from existing RCC slab with adjustable 25 x 4 mm mild steel flats welded at top to reinforcement bars, including exposing the reinforcement bars and making good the damages with cement mortar as specified in the item and drawings.</p> <p>Expanded Metal</p> <p>Expanded metal shall be fixed with the long way of the mesh across the supports. The strands in the various sheets shall all slope in one direction, in vertical work they shall also slope inwards and downwards from the plaster face. To ensure continuity of key at the fixing points small round rods, V-shaped ribs or strips of hardwood shall be fixed on the face of the supports. All sheets shall be lapped not less than 25-mm at the sides and ends, overlaps shall not occur only at supports. Sides of the sheets shall be wired together with galvanized wire of not less than 18 SWG, at every 75 mm between supports. Cut ends of wire used for fastening etc. shall be bent inwards and not towards the plaster finishing coat. The expanded metal shall be secured to supports by means of galvanized staples at intervals of not more than 100-mm. It shall be secured to steelwork by wire or clips.</p> <p>The fixing centres should normally be not greater than 350 mm for mesh weighing 1.2 kg/sq.m. of 10 or 6 mm mesh. Care shall be taken to ensure that the anti corrosion treatment is in good condition after fixing.</p> <p>Gyp board or Boral plaster board</p> <p>The material for installing false ceiling system shall be made of gypsum board with ISO 9002 and ISO 14000 certification, with minimum thickness of 12.5mm (maximum variation in thickness +0.4mm or -0.4mm), with minimum density of 677 kg/cum, with flexural strength not less than 485 N cross directional and 175 N machine directional, with hardness at core, end and edge not less than 65 N, with capacity to withstand breaking load not less than 556 N in longitudinal direction and not less than 275 N in transverse direction. The thermal resistance value "R" shall be not less than 0.45, with fire propagation index "I" not less than 2.1. It shall be fixed to the underside of the suspended grid comprising properly galvanised 0.5mm thick 80mm x 26mm ceiling section to be placed at maximum distance 457mm c/c, 0.5mm thick 20mm x 45mm x 30mm channel along the wall, 0.9mm thick 15mm x 45mm intermediate channel to be placed at maximum distance of 122mm c/c, 0.5mm thick 25mm x 25mm ceiling angle to be placed at maximum distance connecting clip and 22mm x 37mm softie cleat to be fixed at RCC ceiling by using standard screw and proper metal grip, as per drawing, manufacturers' specification, and instruction of engineer, all complete.</p> <p>Finish</p> <p>The ceiling boards free of damages are fixed to the framing in perfect line and level. The joints are sealed with plaster of Paris and non-woven paper tapes without forming any bubble the joints shall be</p>
--	--	---

		<p>finished flush to make the ceiling in one piece. The finished surface shall be smooth and true to plane and curved as required. Once laying of ceiling is completed the dust and floors are cleaned for the painting works.</p> <p>Measurement It shall be measured flat in square meter of the actual area covered.</p> <p>Payment Payment for work will be made on the basis of contract unit price indicated in the BOQ. The payment will be full and final compensation for all material, labor, and equipment to complete the works as specified.</p>
N13	Armstrong Board	<p>The Armstrong fine fissures board of size 600 x 600 x 16 mm or 600 x 1200 x 16 mm size shall be used. The Boards shall have texture and design pattern.</p> <p>The suspenders must conform to Armstrong standard grid. Horizontal and transverse members are galvanized mild steel channel.</p> <p>Construction Procedures The Armstrong ceilings are suspended from the concrete ceilings, and or truss and purling by steel hangers to suspend the horizontal steel channels. The horizontal members are screwed with steel screws and grip in the wall. The suspenders are clamped to the truss and purling with steel screws. After the framing is completed the engineer in charge shall check the framing before allowing fixing the ceiling boards.</p> <p>The Armstrong fine fissures boards free of damages are fixed to the framing in perfect line and level.</p> <p>Once laying of ceiling is completed the dust and floors are cleaned.</p> <p>Measurement Measurement of all the works will be made in m2 of works as specified.</p> <p>Payment Payment for work will be made on the basis of contract unit price indicated in the BOQ.</p> <p>The payment will be full and final compensation for all material, labor, and equipment to complete the works as specified.</p>
N19	Sisam wood wall paneling	<p>This paneling shall be decorative or non-decorative (Paintable) type as per design and thickness specified by the Engineer-in-Charge</p> <p>The ornamental wood work shall be painted on the back with priming coat of approved wood primer before fixing the same to the grounds with screws, which shall be sunk into the wood work and their tops covered with putty. The ornamental work shall be made true and accurate to the dimensions shown in the working drawings. The fixing shall be done true to lines and levels. The planks for wall lining shall be tongued and grooved, unless otherwise specified.</p> <p>Measurements Wall paneling shall be measured in square metre nearest to two places of decimal.</p>

		<p>Rate The rate includes the cost of materials and labor required for all the operation described above.</p>
N20 – N23	Prefab Panel	<p>Providing and fixing the prefabricated concrete panel of 50mm to 75mm thickness with tongue groove joint on metal channel with all accessories, for interior and exterior walls for dry construction.</p> <p>Application: Panels pre casted as solid reinforced precast concrete (flat panels), or as reinforced concrete ribbed panels with a thin exterior shell of specified thickness as approved by the site engineer shall be used. 75 mm thick panels shall be used for the external wall and 50 mm thick panels for internal partition walls shall be used or as specified in the design. Engineering and energy performance documentation of the material shall be submitted to the site engineer for approval. Standard panels (2.4 m x 0.6 m, 2.7 m x 0.6 m, 3 m x 0.6 m) shall be laid in the metal channels as per manufacturers' specification with approval of site engineer to</p> <p>Protection Protect installed products shall be protected until completion of project. Damaged products shall be touched-up, repaired or replaced before Substantial Completion</p> <p>Measurement: It shall be done in exact square meter of the area done after deducting the openings.</p> <p>Rate Rate shall be for all the works including all Connections, bracing, reinforcement, labor and materials.</p>
N24, N25	UPVC partition board	Refer UPVC door and windows
N26, N27	Aluminum partition	Refer Aluminum door and windows
11. O. Road Works / P. Gabion Works		
		Refer to Detailed Specification of relative departmental documents

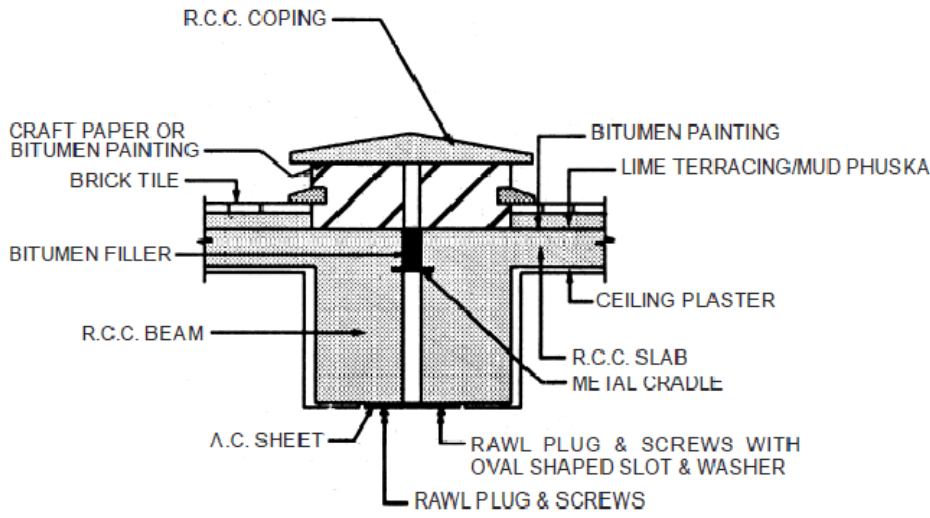

Fig. 5.11 : Details of Raised Type Expansion Joint at Roof

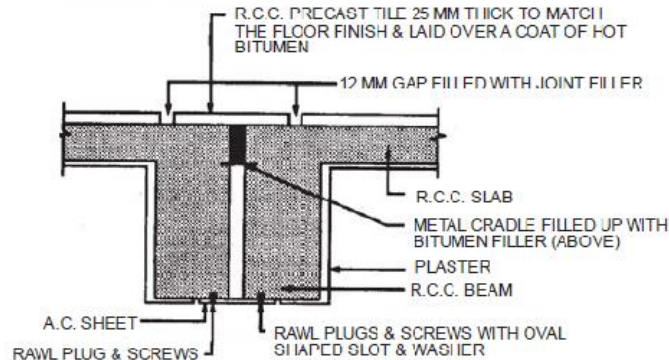

Fig. 5.12 : Typical Details of Expansion Joint at Floor

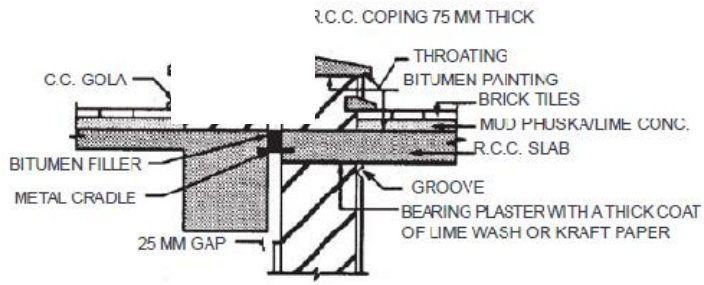

Fig. 5.13 : Typical Details of Expansion Joint at Wall & Beam Junction

LIST OF APPROVED MAKES (Example only)

Sl.No.	MATERIALS	MANUFACTURERS
1.	Doors & Windows fixtures/ Fittings:	Everite, Hardima, Earl Bihari
2.	Door Closer / Floor spring :	Doorking, Everite, Hardwyn, Amar Darmy.
3.	Aluminum Sections. :	Indal , Bhoruka, Hindalco, Jindal
4.	Clear Glass/ Clear Float Glass : Toughened Glass	Modi, Gujrat Guardian, Tata, Saint Gobain(SG)
5.	Laminates :	Formica, Decolam, Century, Marino, National, Green Ply
6.	Synthetic Enamel Paints :	Berger (Luxol gold), Asian(Apcolite), ICI Dulux (Gloss), Nerolac (Full gloss hard drying)
7.	Oil Bound Distemper :	Asian (Tractor), Berger (Bison), Nerolac (Super Acrylic).
8.	Cement Paint :	Snowcem Plus, Berger (Durocem Extra), Nerolac (Nerocem with titanium),.
9.	Plastic Emulsion Paint :	ICI, Asian, Nerolac
10.	Other Paints/Primers :	ICI Dulux, Asian, Berger, Nerolac
11.	Cement : OPC 43 grade	conforming to BIS-8112 and approval of Engineer
12.	Reinforcement Steel :	TMT steel conforming to BIS-1786 and approval of source by Engineer
13.	Glass Mosaic Tiles :	Italia, Bizzaza. Pallidio
14.	Back-up Rod. :	Supreme Industries or equivalent
15.	M.S. Pipe :	Jindal Hisar, Prakash-Surya, BST, Kalinga
16.	Polysulphide sealant. :	Pidilite, Fosroc, Choskey, Chematal Rai
17.	Polycarbonate Sheets :	GE Plastics or approved equivalent
18.	Metal Fire Check Doors :	Navair, Shakti-met, Godrej, Pacific Fire Control, Promat
19.	Gypsum Board System :	India Gypsum, Laffarge, Boral
20.	Sunken Portion Treatment :	Choksey, Roffe, Krytone,Sika
21.	Admixtures for concrete. :	Cico, Vam Organics, Roffe, Pidilite
22.	Epoxy Paint. :	Nerolac, Shalimar or approved equivalent.
23.	Ceramic Tiles :	Johnson, Somany, Kajaria, Spartek, Nitco, Orient
24.	Pre-Laminated Particle Board :	Novopan, Greenlam, Kitlam,Bhutan Board.
25.	Flush Door Shutters. :	Century, Kitply, Novapan, GIC Goyal, Green Ply
26.	Silicon Treatment :	GE-Silicon, Pidilite, Choksey, Wacker, Forsoc
27.	Glazed Tiles :	Bell, Somany, Johnson, Kajaria, Cera.
28.	PVC Water Stops :	Supreme, Fixopan or approved equivalent
29.	White Cement. :	Birla White, J.K.
30.	Powder Coating Material Pure Polyester. :	Jotun , Berger, Goodlass Nerolac
31.	Masking Tapes :	Suncontrol , Wonder Polymer.
32.	Stainless Steel Screws For Fabrication and fixing of Windows.:	Kundan , Puja , Atul.
33.	Proposed Treatment on MS Brackets. : gms./sqm.(microns) 80-90	Galvanised Brackets As per IS:4759-1996 610
34.	Dash Fasteners./Anchor bolts :	Hilti, Fischer, Bosch.
35.	Stainless Steel Bolts, Washers Nuts. :	Kundan, Puja, Atul.

36. Stainless Steel Pressure Plate Screws. :	Kundan, Puja, Atul.
37. Stainless Steel Friction Stay. :	Securistyle, Earl Bihari.
38. E.P.D.M. Gaskets. :	Anand Reddiplex, Enviro Seals
39. Weather Silicon. :	Dow Corning, Wacker, GE
40. Structural Silicon at butt joints :	- Do -
41. PVC continous fillet for periphery packing of Glazings /Structural glazings.:	Roop, Anand, Forex Plastic.
42. Floor Springs. :	Doorking, Opel.
43. Aluminum Cleat arrangement for Glazings. :	Deco or approved equivalent
44. Water proofing / Injection Grouting :	Overseas Water Proofing Corporation
45. 6mm thick Reflective Glass :	Glaverbel, Glavermas, Saint Gobain.
46. Door Locks. :	ACME, Godrej, Harrison
47. Door Seal – Woolpile Weather Strip :	Anand -Reddiplex.
48. Aluminum Grill :	Decogrille and approved Equivalent
49. Vitrified Porcelene Tiles: :	Restile (Granamite- Atena), Naveen, Bell-Ceramics, Kajaria, Somani
50. Carpets :	Hollitex, Standard, Mohawk
51. Aluminum Cladding sheets :	Alstrong , Alpolic, Alucobond,
52. Aluminum Die-cast handles : & two point locking kit	Giesse, Securistyle, Alu-alpha
53. Stainless steel D-handles :	D-line, Giesse, Dorma
54. Auditorium Chairs :	Penworker, Suri Cine chairs, Godrej
55. Woollen Fabric for Auditorium :	ESSMA, Raymonds
56. Stainless Steel Pipes/Flats :	304 Grade
57. Structural Steel :	Conforming to BIS 2062 and approval by Engineer
58. Ready Mix Concrete :	L&T,ACC,BIRLA,AHLCON
59. Antistatic Epoxy Floor :	Fosrock, Beck, Famaflor, STP
60. SBS bitumen based Self adhesive membrane Material :	Grace-Bituthene CP1.5, Texsa-Texself 1.5
61. Acoustic Mineral Fibre :	USG-Radar, Armstrong, 21st Century, Acostyle
62. APP modified Bitumen water proofing membrane :	Lloyds, STP, Bitumat
63. Hand made ceramic tiles :	Raja Tiles, Saraswathi
64. Curtain wall :	Specialised Agency to be Approved by Engineer
65. Fire Panic bar :	Briton, Monarch, Von-Duprin
66 Ply board :	Greenply, Kitply, Century
67 PVC Doors :	Rajshri or approved equivalent

Note : Wherever makes have not been specified for certain items, the same shall be as per National Standard and as per approval of Engineer